



Electric Autoclave EA 6-2



Instruction Manual

The company reserves the right to change equipment specifications and models without notice. Pictures are representative and may not be part of the standard equipment.

Elgi Rubber Company Limited

2000 Trichy Road • Coimbatore 641 005 • Tamil Nadu • India • +91 (422) 232 1000 • info@in.elgirubber.com • www.elgirubber.com

Foreword

Bonding of precured treads to the tyre at a temperature much lower than the conventional mold-cure system can be achieved by using the Electric Autoclave EA 6-2. Electrical heaters provided inside the chamber heat up compressed air, which in turn heat the special low temperature cushion gum in between the tyre and the tread. This results in a perfect bond.

The efficient heating, controlling and insulating system in this equipment helps in reducing the processing cost. It is possible to set the cure parameters like temperature and pressure precisely to produce quality retreads.

Contents

01 Description	4
02 Specifications	6
03 Assembly and Commissioning Tools	8
04 Installation and Commissioning	9
05 Pre-Operation Checks	10
06 Operation	11
07 Do's and Don'ts	16
08 Troubleshooting	17
09 Preventive Maintenance	20
10 Electrical Drawings	21
11 Pneumatic Circuit	38
12 Parts List	40
13 Essential Spares List	45

01 Description

The Electric Autoclave EA 6-2 consists of the following major components:

Chamber

The electric tyre curing chamber is a well insulated horizontal vessel. This contains heaters to heat compressed air and a fan driven by a motor to circulate the hot air inside the chamber. Manual locking pins lock the clamps that secure the door to the electric chamber. The locking pins will not allow the clamps to open when the chamber is under load.

The chamber is fitted with control devices for temperature and pressure. The door is locked by a pneumatic device which is easy to handle, safe and foolproof.

The handles of the locking pins also actuate the exhaust valves of the chamber. When the pins are not locked, the exhaust remains open, thus preventing the chamber from becoming pressurised.

There is a specially designed forced air circulation system for maintaining uniform temperature throughout the autoclave.

An overhead monorail system makes it easy for loading and unloading the tyres. A pneumatic cylinder is provided in the monorail to lift the tyre and rim assembly, thus reducing manual operation. The monorail has a provision to accommodate tyres which are to be cured on one side as well as tyres which have already been cured and taken out on the other side simultaneously.

Automation Kit

This is a provision made for auto inflation / deflation of the chamber and tyre pressure. It can be controlled by the PLC.

MEP System

The modulated envelope pressure (differential pressure system - or dual pressure system) is the third pressure given to the envelope. This can be selected on the PLC touch screen and the machine can be set on vacuum / vent / MEP.

02 Specifications

Model	EA 6-2 02/60	EA 6-2 04/60
Number of Tyres (based on 12.00-24.00 or 315/80R22.5)	2	4
Catalogue Number	MC56 62 - AX*	MC56 62 - BX*
Electrical Load		
Heater (kW / hp)	12 / 16	18 / 24
Blower (kW / hp)	3.7 / 5	7.5 / 10
Air Pressure Requirement (kg/cm ² / psi)	8.0-10.0 / 114-142	8.0-10.0 / 114-142
Working Temperature (°C)	100 - 125	100 - 125
Dimensions (L x W x H) (mm)	900 x 1900 x 2316	4640 x 1900 x 2316
Weight (kg)	~1800	~2700
X* in Cat. No. denotes power supply specifications (V / Hz / ph)	R - 220 / 60 / 3 O - 380 / 50 / 3 S - 380 / 60 / 3 P - 415 / 50 / 3 U - 440 / 60 / 3	R - 220 / 60 / 3 O - 380 / 50 / 3 S - 380 / 60 / 3 P - 415 / 50 / 3 U - 440 / 60 / 3
Installation	Free standing	Free standing

EA 6-2 07/60	EA 6-2 11/60	EA 6-2 24/60
7	11	24
MC56 62 - CX*	MC56 62 - DX*	MC56 62 - FX*
18 / 24	36 / 48	72 / 96
7.5 / 10	7.5 / 10	15 / 20
8.0-10.0 / 114-142	8.0-10.0 / 114-142	8.0-10.0 / 114-142
100 - 125	100 - 125	100 - 125
5650 x 1900 x 2316	7800 x 1900 x 2316	12100 x 1900 x 2316
~3600	~4400	~8000
R - 220 / 60 / 3	R - 220 / 60 / 3	R - 220 / 60 / 3
O - 380 / 50 / 3	O - 380 / 50 / 3	O - 380 / 50 / 3
S - 380 / 60 / 3	S - 380 / 60 / 3	S - 380 / 60 / 3
P - 415 / 50 / 3	P - 415 / 50 / 3	P - 415 / 50 / 3
U - 440 / 60 / 3	U - 440 / 60 / 3	U - 440 / 60 / 3
Free standing	Free standing	Free standing

03 Assembly and Commissioning Tools

Accessories

Standard	Installation kit
Optional	<ol style="list-style-type: none"> 1. Cure law cycle recorder 2. Facility for remote monitoring, data logging and email alerts

Tools

Spanners - double end 6 - 36 mm	1 Set
Screw driver - 6", 8" & 10"	1 No. each
Line tester	1 No.
Allen keys (mm)	1 Set
Combination plier - 10"	1 No.
Nylon hammer	1 No.
Pipe wrench - 18"	1 No.
Adjustable spanner - 12"	1 No.
Grease gun	1 No.

Materials

Electrical cable	<ul style="list-style-type: none"> • For 102/60,104/60 and 107/60 - 4core, 10 sq.mm • For 111/60 and 124/60 - 125A, 4 core, 16 sq.mm <p>UG electrical cable from the distribution board to the chamber with suitable earthing and protection devices</p>
Air line	$\frac{3}{4}$ " air line with a minimum pressure of 10.0 kg/cm ² from the nearest tapping point
Silicon grease	1 kg
Lubricating oil (SAE 20)	$\frac{1}{4}$ L
Multi-purpose grease	$\frac{1}{4}$ kg

04 Installation and Commissioning

Positioning

- Mark a location for the chamber and monorail columns as per the plant layout.
- Prepare a foundation for the monorail column well in advance to facilitate the setting of concrete.
- Move the Electric Autoclave and position it at the marked location.
- Fix the monorail column on the foundation bolts. Then fix the tracks on the columns and fasten the structure.

Connection

- Fix one end of the channel to the monorail and the other end of the bridge channel to the end of the monorail system inside the chamber. The monorail and chamber should be in line with each other while fixing the bridge channel, and should fit in smoothly.
- Mount the Electrical panel board to the machine and fasten the bolts, if sent separately.
- Connect the motor terminals to the strip connector provided inside the panel.
- Connect the heater cable ends to the terminal adopter on the machine.
- Connect the thermocouple wire ends to the Radix temperature controller as per the drawing. Ensure that the polarity is connected properly.
- Connect the incoming cable mainline to the strip connector of the panel board (R, Y, B, N points).
- From the nearest air line point, take a tapping through a $\frac{3}{4}$ " GI pipe and connect it to the main air line point provided on the chamber.
- Connect the pneumatic hoses for the door locking system, the cylinders, the 'U' seal and inlet / outlet of the chamber.
- Fix the safety valves on chamber and line pressure. Chamber safety valve is 90 psi and line pressure safety valve is 12 psi.

Setting

- Set the pressure regulator of incoming air line to 8.1 kg/cm².
- Set the pressure regulator for chamber pressure to 6 kg/cm² (85 psi).
- Set the temperature controller to 125°C.
- Tighten all the electrical points inside the electrical panel board.

05 Pre-Operation Checks

- Switch on the mains and check if the indicator lamps are working.
- Check the voltage in each phase using the voltmeter rotary switch.
- Switch on the Blower motor and check the direction of the rotation. Correct if necessary by interchanging phases.
- Switch on the heaters and check if they are working by operating the ammeter rotary switch. The amperage should be more or less the same on all phases.
- Check if the incoming air line is 8.1 kg/cm².
- Operate the hand lever valve of door and see whether the door locks are functioning smoothly.
- Check if the temperature controller is connected properly and see if the reading is correct.
- Close the door, operate the 'U' seal and check for any leakage of air.
- Check if all the gauges are functioning without any error.
- Run a dry trial of the chamber to see if all the controls like pressure regulators, temperature controllers, etc. are functioning.
- Check if there is a leakage of air from the gland packing at the rear side of the chamber.

06 Operation

Loading of Tyres

- Link the autoclave loading system and autoclave with bridge rail.
- Load the tyres into the chamber, connect the tyre inflation and envelope exhaust quick couplers, and insert a safety pin in the chamber monorail.
- Close the door and operate the door lock air valve to clamp it with the chamber. Insert the tyre air pressure and the chamber air pressure safety lock pins on both sides and turn through 90 degrees to close the exhaust valves provided in the door locks.
- Keep all the valves for tyre inflation and envelope exhaust close.
- Pressurise the door U Seal by opening the valve.
- Select Mode to MEP.
- Curing system selection is pre-set based on customer requirements. For any changes in the curing system requirement, contact Elgi.
- Turn ON the Motor switch.
- Turn ON the Heater switch.

Curing

- Check if all the pressure gauges read the correct pressure as given in the curing parameters chart.
- Check the envelope exhaust drain cocks and the tyre inflation pressure gauges for any leakage in the envelope or curing bag every 15 minutes.
- If an envelope leaks, air rushes out of the envelope exhaust drain cock. Then that particular drain cock should be closed (noting which tyre is connected to that line - as that tyre will not be properly cured and will need to be rerun).
- If a curing bag fails, the tyre pressure gauge will show less pressure. Then the particular tyre air inlet valve and envelope exhaust drain cock should be closed. If the failure occurs within 30 minutes of starting, exhaust the chamber and tyre, remove the tyres, replace the failed curing bag or envelope and restart.
- Curing time starts automatically when the chamber temperature reaches the set curing temperature. The curing time starts from this moment onwards. It may take a little longer to attain set curing temperature in a cold start than in subsequent charges.
- Check if the temperature controller maintains the set temperature by switching the heaters OFF and ON automatically.

Note: For curing parameters, follow rubber raw material as per manufacturers specifications.

Unloading of Tyres

- When the curing time is over, the machine will automatically stop. The tower light will glow and the alarm will go off.
- Auto Deflation System - Tyre and Chamber pressure will automatically deflate.
- Turn the chamber and tyre safety lock pin through 90 degrees to exhaust the air pressure.
- Ensure the chamber air pressure is completely exhausted.
- Deflate the door U Seal.
- Remove the safety lock pins and unlock the chamber by operating the door lock air valve.
- Open the door. Remove the safety pin from the chamber monorail. Link the monorail and chamber with bridge rail.
- Disconnect the tyre inflation and the envelope exhaust quick couplers and remove the tyres.

MEP - Operating Sequence

1. Check the envelopes for leakage (vacuum test), this must be done when the tyres are on the monorail.
2. While loading the tyres into the chamber make sure the quick coupler is connected properly to the envelope mouth adaptor. Air inside the envelope will be evacuated through the header, and the vacuum pump may run intermittently maintaining the pressure in the vacuum tank.
3. Close and lock the door and the safety valves.
4. Inflate the door seal.
5. Switch ON the blower and heater.
6. Choose MEP on the HMI panel and this will switch on the pump and evacuate the air in the envelope header. The compound pressure gauge will indicate negative pressure.
7. After the chamber pressure has reached the set pressure (4 kg/cm) and ² approximately 20 minutes from start of blower, the MEP will start and this will pressurise the envelope header and the pressure will be maintained at 4.5 kg/cm²(i.e) 1.5 kg/cm less than the chamber pressure 6 kg/cm. This will continue till end of the curing cycle.
8. On completion of the curing cycle the auto inflation system will automatically discharge the air in the chamber and the tyre. If there is no auto inflation system, then switch OFF the blower and heater and discharge the air manually. During this time the air in the envelope will also be discharged automatically.
9. Open the door and unload the tyres.
10. Repeat the step 1 to 9 for the next curing cycle.

MEP System - Description

In an ordinary electric chamber curing system (without MEP), the envelope is pushed into the bottom of the tread grooves by the chamber air pressure.

In MEP System, after the cushion rubber begins to flow, the dual pressure ensures that the envelope isn't pushed into the bottom of the tread grooves. Inside the tread grooves there is a cushion of air over which the chamber air pressure exerts an even distribution of pressure in all directions and all corners of the bottom of the tread grooves and permits the cushion rubber to flow evenly, preventing a condition referred to in the industry as 'peaking'.

MEPC Logic

The supply consists of a Chamber and a Vacuum Tank.

The Vacuum Tank consists of a Vacuum Pump, a Vacuum Pressure Switch (VPS), a Starter (Q1 & e2) and a Vacuum Gauge. As seen in the circuit, by switching on the supply (SW3) and keeping the selector (S/S) in position 1 (vacuum) or 3 (MEPC), the vacuum pump will work until it reaches the set point in VPS and it maintains vacuum in the tank.

During the process, if the selector (S/S) is under vacuum, then the Solenoid Valve SV8 (for opening and closing of vacuum line) is always open and the VPS maintains vacuum.

If the selector is in MEPC position then the operation is as follows:

The Differential Pressure Switch (DPS) is connected across the chamber and the envelope header. If the pressure difference is above the set pressure (eg. 20 psi) then the contacts of DPS will be switched.

When the Blower motor has been switched ON, the Relay R1 will be energised and the MEPC starts. Until the Pressure Switch PS (set to about 4.5 kg/cm) switches and the Timer T1 elapses, the vacuum header will be evacuated and maintained. As soon as these two conditions are met, through the contacts of DPS and Timer T2 (T2 limits the frequency of inflation and deflation in the envelope header), the Solenoid Valve SV10 (SV10 is intended for the inflation of the envelope header) opens and hot air will be let into the envelope header.

Now the pressure in the envelope header increases and hence the pressure difference between the chamber and the envelope header comes down. When this is below the set pressure (say 20 psi), the DPS switches to normal position and this in turn will de-energise the Solenoid Valve SV9 (SV9 is a normal open valve and is used to exhaust the air from the envelope header). The air exhausts from the envelope header. Now the pressure difference builds up and the SV10 energises and inflates the envelope header. This operation of SV9 and SV10 repeats till the end of the curing cycle. Thus the pressure difference is maintained with fresh hot air. At some point, when the curing completes the blower motor will switch OFF automatically and the Timer T3 (delay timer for preparation of next curing cycle) switches OFF while SV9 exhausts the air in the envelope header and makes the system ready for the next cycle.

MEP Trouble Shooting

Problem and probable causes

In case of envelope sealing failure or puncture the chamber air pressure will enter inside the envelope and the MEP pressure gauge will read the FULL chamber air pressure 6 kg/cm / 85 psi instead of MEPC pressure 4.8 kg/cm²/ 70 psi.

Action

In case a failure is noticed at the start of curing cycle, deflate the tyre and chamber pressure, unload the problematic tyre and check for envelope sealing failure / puncture. After correcting the problem, check the envelope sealing once again using the vacuum pump and then continue the curing cycle.

In case a failure is noticed in the middle of curing cycle in any one of the tyres, close the MEPC control inlet ball valve from the shared header line and open the outlet ball valve for that particular tyre to continue the curing cycle as regular curing cycle without MEPC system for that particular tyre. Make note of the particular tyre, as it is probable that the cushion rubber will not have properly vulcanised and the tyre will need to be rerun.

Important note

MEPC SYSTEM pressure is 1.5 kg/cm² / 15 psi lesser than the chamber air pressure being maintained.

07 Do's and Don'ts

Do's

- Always keep the machine and surrounding area clean.
- The moving parts should be well lubricated.
- Keep the filter's bowl clean.
- Maintain the set pressure for tube inflation and chamber pressure.
- While inserting the quick coupler to the adapters, ensure that they are inserted tightly.
- Replace the washer of the quick coupler weekly or when the leakage starts.
- Open the chamber door only after all the air from inside is released.
- Always keep the drain cocks of the exhaust open while in operation.
- Keep the door closed when the chamber is not in operation.
- Always cure passenger tyres separately. Do not combine with truck tyres and light commercial vehicle tyres.
- Clean and lube the chamber door U seal grooves and U seal regularly.

Don'ts

- Do not inflate the tyres before the chamber door is locked and pressurised.
- Do not over tighten the gland packing.
- Do not change the polarity of the temperature gauge and the setting.
- Do not open the outlet of the seal's drain cock while the chamber is pressurised.
- Do not open the chamber door while in operation.
- Do not connect a worn out quick couple. Replace the washer.
- Do not adjust the set pressure after the initial setting is done.
- Do not operate the Blower Motor and Heater when voltage is below normal (380 V).
- Do not open the electrical panel board without switching off the mains.

08 Troubleshooting

Symptoms / Problems	Possible Causes	Remedies
Machine fails to start (motor not working)	<ol style="list-style-type: none"> 1. No incoming supply 2. Main switch not put 'ON' 3. No supply to contactor 4. Problem in the circuit 	<ol style="list-style-type: none"> 1. Check incoming supply 2. Put on main switch 3. Check fuse, contactor, etc. 4. Check electrical circuit and reset the relay
Heaters not working	<ol style="list-style-type: none"> 1. Loose connection at terminal block 2. Contactor not working 3. Heaters have failed 	<ol style="list-style-type: none"> 1. Rectify loose connections at terminals 2. Check and rectify 3. Replace heaters
Motor getting too hot	<ol style="list-style-type: none"> 1. Wrong alignment 2. Bearings are worn out 3. Weak coil 4. Very low incoming voltage 5. Gland packing very tight 	<ol style="list-style-type: none"> 1. Check the alignment of the motor 2. Remove motor and check the bearing 3. Check the coil of the motor with a Meter Rewind if necessary. Before refitting, check the connection to the motor. 4. Check incoming voltage and rectify 5. Loosen the gland packing adjustable bolts
Temperature controller indicating negative reading	<ol style="list-style-type: none"> 1. Wrong connection at thermocouple 	<ol style="list-style-type: none"> 1. Check and rectify connection (interchange polarity) - refer diagram

Symptoms / Problems	Possible Causes	Remedies
Temperature controller not working	<ol style="list-style-type: none"> 1. No incoming line 2. Relays inside may not be working 	<ol style="list-style-type: none"> 1. Check incoming line 2. Remove the cover and check the circuit inside. Do not tamper calibration. Instruments should be checked by only experienced personnel.
Chamber pressure gauge indicating	<ol style="list-style-type: none"> 1. Very low pressure 2. Leakages in hoses 3. Defective regulator 4. Chamber outlet valve may be kept open 5. Gauge is defective 	<ol style="list-style-type: none"> 1. Check line pressure 2. Check and rectify 3. Check and rectify 4. Check the valve and correct 5. Replace gauge
Door locking system not working	<ol style="list-style-type: none"> 1. Air hose leakage 2. Insufficient air pressure 	<ol style="list-style-type: none"> 1. Check and replace the hose if required 2. Check incoming air pressure, the pressure should 8.1 kg/cm² 3. Check and replace 4. Loosen the door fixing bolts on the swivel arm, seat the door against the chamber and tighten the bolts
Heavy leakage of air from the envelope	<ol style="list-style-type: none"> 1. Envelope failure 2. Envelope not sealed properly 3. Coupler not inserted properly 4. Quick coupler washer worn out 	<ol style="list-style-type: none"> 1. Check and replace 2. Check and rectify 3. Check and insert properly 4. Replace washer



Symptoms / Problems	Possible Causes	Remedies
Air leaking from the fan shaft at the rear end	<ol style="list-style-type: none"> 1. Gland packing worn out 2. Wrong alignment 	<ol style="list-style-type: none"> 1. Check and replace with new ones (while refitting, do not over tighten) 2. Check alignment and rectify
Fan running with a lot of noise and vibration	<ol style="list-style-type: none"> 1. Key loose in the fan shaft 2. Fan touching with the body of the machine 3. Fan is not balanced 	<ol style="list-style-type: none"> 1. Remove cover and check the fan assembly. Check and replace key if required. There should be no play. 2. Remove cover and check and rectify 3. Rotate the fan and allow to stop. If found to oscillate before stopping, balance the fan and then assemble.
Takes a very long time to attain the required temperature	<ol style="list-style-type: none"> 1. Excess heat loss - leakage from gland packing or envelope exhaust drain cocks and the 'U' seal 2. Some of the heaters may not be working 	<ol style="list-style-type: none"> 1. Check if there is any leakage. There should not be any leakage. 2. Check and rectify the same

09 Preventive Maintenance

Name of the Post	Curing
Name of the Equipment	Electric Autoclave
Model No.	EA 6-3

S. No.	Activity	Frequency	Acceptance Criteria
1	Clean the machine	Daily	Dust free
2	Drain the water from the air filter	Daily	No water in the filter unit
3	Check the air lines, hoses, couplers, gauges and connectors for leakage	Daily	No leakage
4	Check the air pressure for curing bag 8 kg/cm ²	Daily	Pressure to be at - 8 ± 0.5 kg/cm ²
5	Check the air pressure for chamber inflation 6 kg/cm ²	Daily	Pressure to be at - 6 ± 0.5 kg/cm ²
6	Check if the gland packing is leaking	Daily	No leakage from motor shaft
7	Check the level of oil in vacuum pump	Daily	Upto visible level in sight glass
8	Check for proper door alignment	Daily	Door should be locked properly & no air leakage
9	Check all electrical connection are tight	Weekly	No loose connection in electrical panel board
10	Check the door U - Seal for proper seating and sealing	Weekly	No leakage from door & no wear & tear in U-Seal
11	Open the cover of heater terminal adopter and check for any loose connection	Weekly	No loose connection in adopter
12	Change the washer of the quick coupler if necessary	Weekly	No leakage of air
13	Grease the plumber block with multi-purpose grease	Weekly	Properly lubricated
14	Check for the noiseless and vibration free running of blower fan	Weekly	Free from noise and vibration
15	Clean and lightly apply silicon grease on the door seal and groove	Weekly	Properly lubricated
16	Check the functioning of all safety valves	Yearly	All safety valve operate at its set value
17	Calibrate the temperature controller	Yearly	Accuracy of chamber temperature
18	Remove duct and check heater terminal, cracked / loose terminal adopters and fiber glass sleeve and replace if necessary	Yearly	No loose, damage, worn out parts

10 Electrical Drawings

6	7	8	9	10	11	12	13	14	15	16	17	18	
<p>Elgi Rubber Company Limited</p> <p>641005 Coimbatore Phone: 9894510000</p>													
													
<p>Company / customer Columbia</p> <p>Project description Electric Autoclave AE3 111/60 380-440V 50/60 HZ 24V DC Control</p> <p>Drawing number 2540151001</p> <p>Commission Elgi</p>													
<p>Item code & Description 03040410139147 Control panel board assembly (Logo PLC) 11T/36 Kw 380-440v 50/60 HZ 24V DC Control</p>													
<p>Created on 27.11.14</p> <p>Edit date Number of pages 17</p>													
													
<p>DESCRIPTION : CONTROL PANEL BOARD ASSEMBLY (LOGO PLC) 11T/18KW 380-440V 24V DC CONTROL</p> <p>ITEM CODE : 03040410139147</p>													
		DATE		27.11.14		DRAWN		SS		DRG. No. :		2540151001	
REV.		DATE		NAME		CHKD.		BSR		SHEET No. :		1 OF 17	
1		07.04.15		SS		APPD.		SGK		TITLE PAGE		A4	

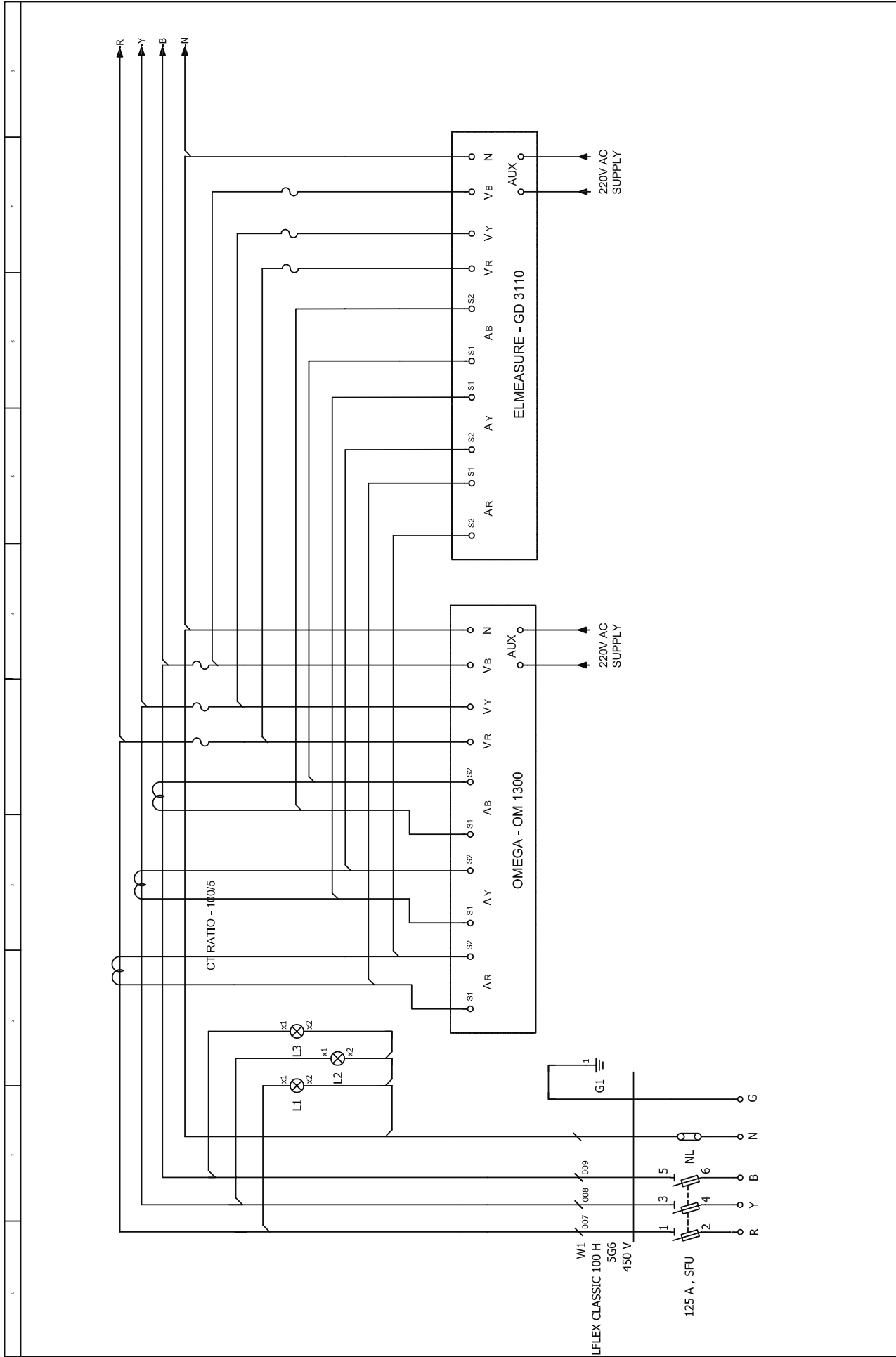

DATE		27.11.14	DESCRIPTION:		POWER CIRCUIT		DRG. No. :		2540151001
DRAWN		SS	CONTROL PANEL BOARD ASSEMBLY (LOGO PLC) 11T/ 18KW 380-440V 24V DC CONTROL		ELGI		SHEET No. : 2 OF 17		A4
CHKD.		BSR	ITEM CODE : 03040410139147						
REV.	DATE	NAME	APPD.	SGK					
1	07.04.15	SS							

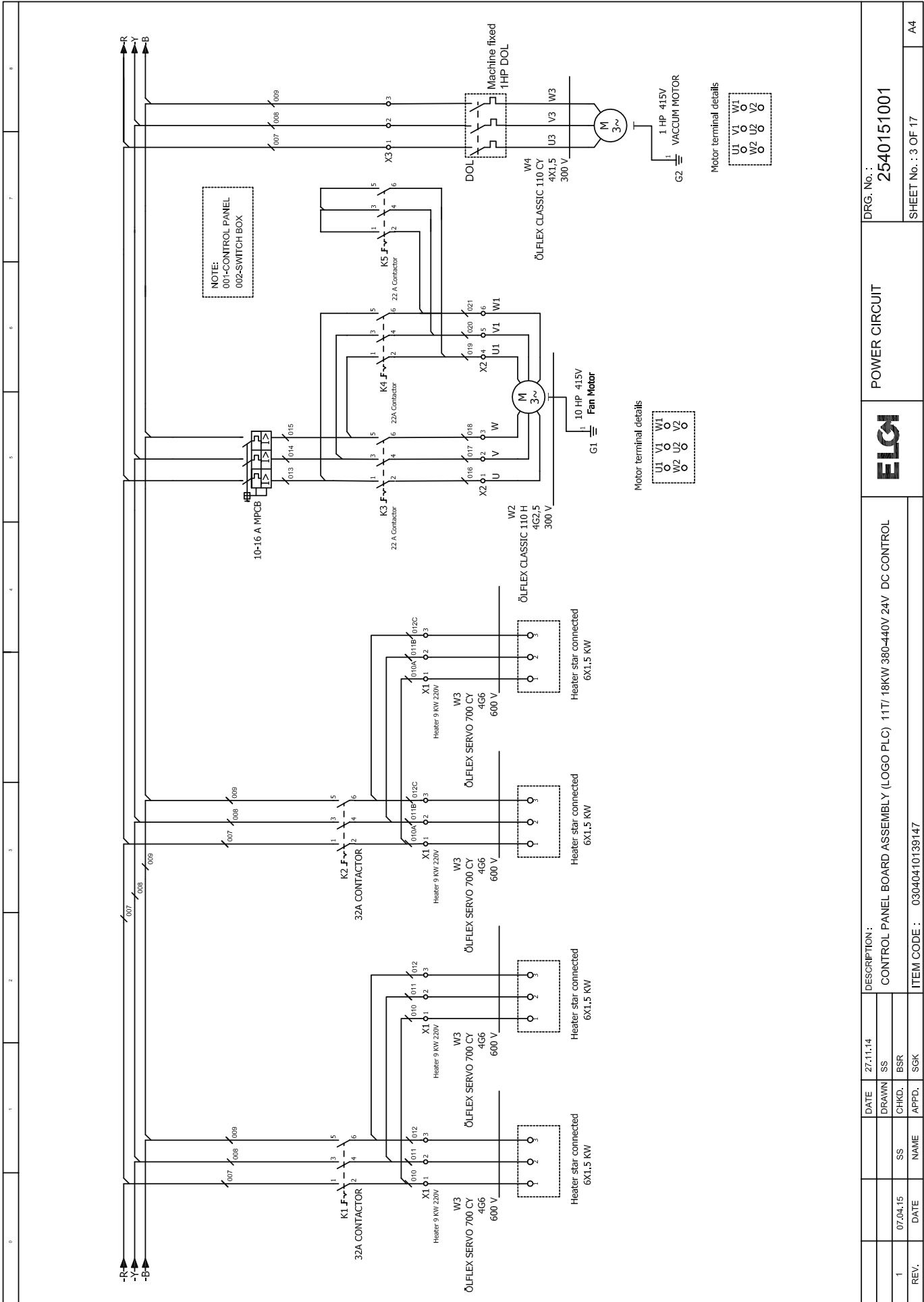

DATE		27.11.14	DESCRIPTION:		POWER CIRCUIT		DRG. No. :	2540151001
DRAWN		SS	CONTROL PANEL BOARD ASSEMBLY (LOGO PLC) 11T/ 18KW 380-440V 24V DC CONTROL		ELGI		SHEET No. : 3 OF 17	
CHKD.		BSR	ITEM CODE : 03040410139147				A4	
REV.	DATE	NAME	APPD.	SGK				
1	07.04.15	SS						

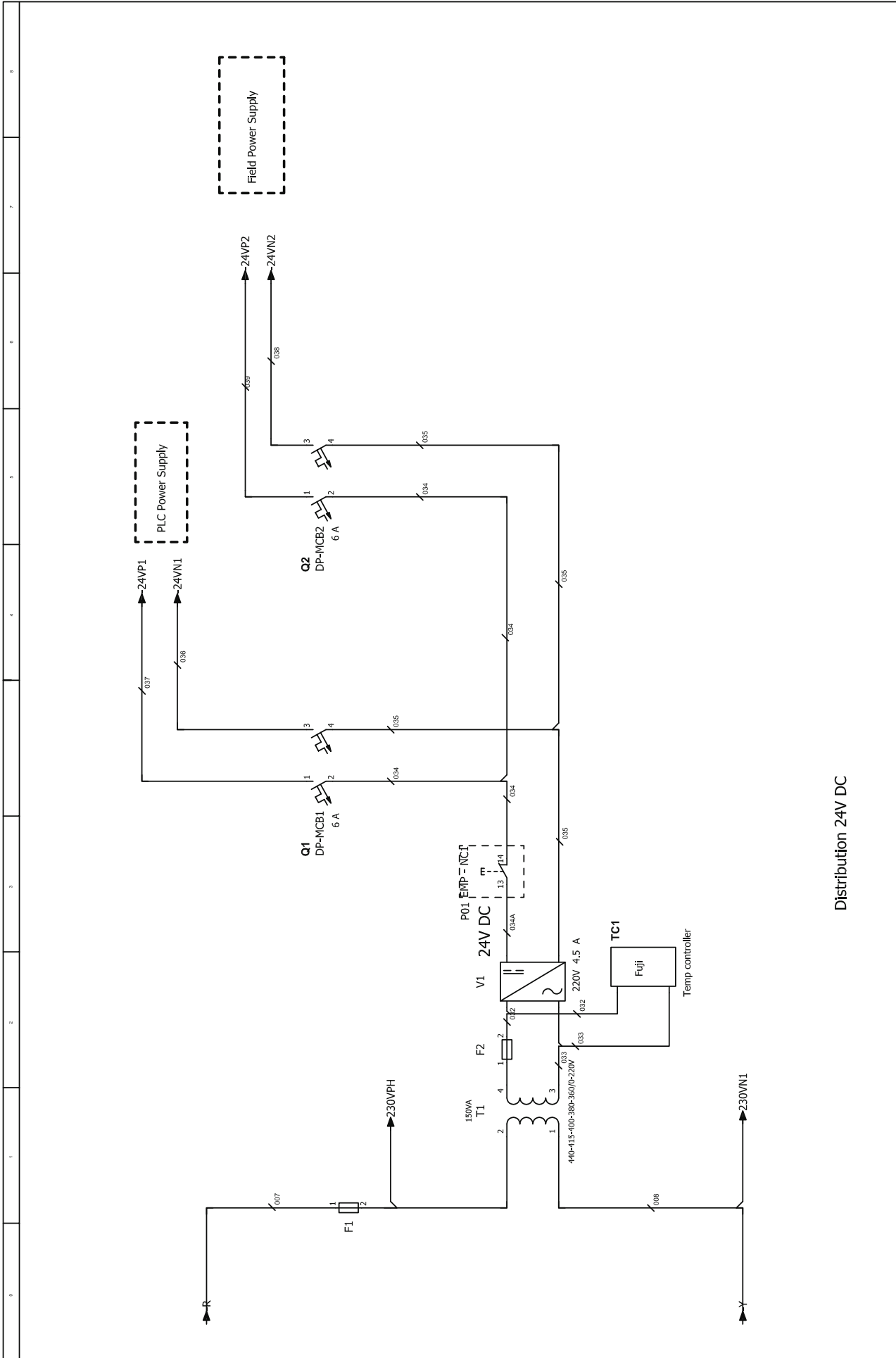

Distribution 24V DC

DATE		27.11.14	DESCRIPTION:		CONTROL SUPPLY		DRG. No. : 2540151001	
DRAWN		SS	CONTROL PANEL BOARD ASSEMBLY (LOGO PLC) 11T/ 18KW 380-440V 24V DC CONTROL		ELGI		SHEET No. : 4 OF 17	
CHKD.		BSR	ITEM CODE : 03040410139147				A4	
REV.	DATE	NAME	APPD.	SGK				
1	07.04.15	SS	BSR					

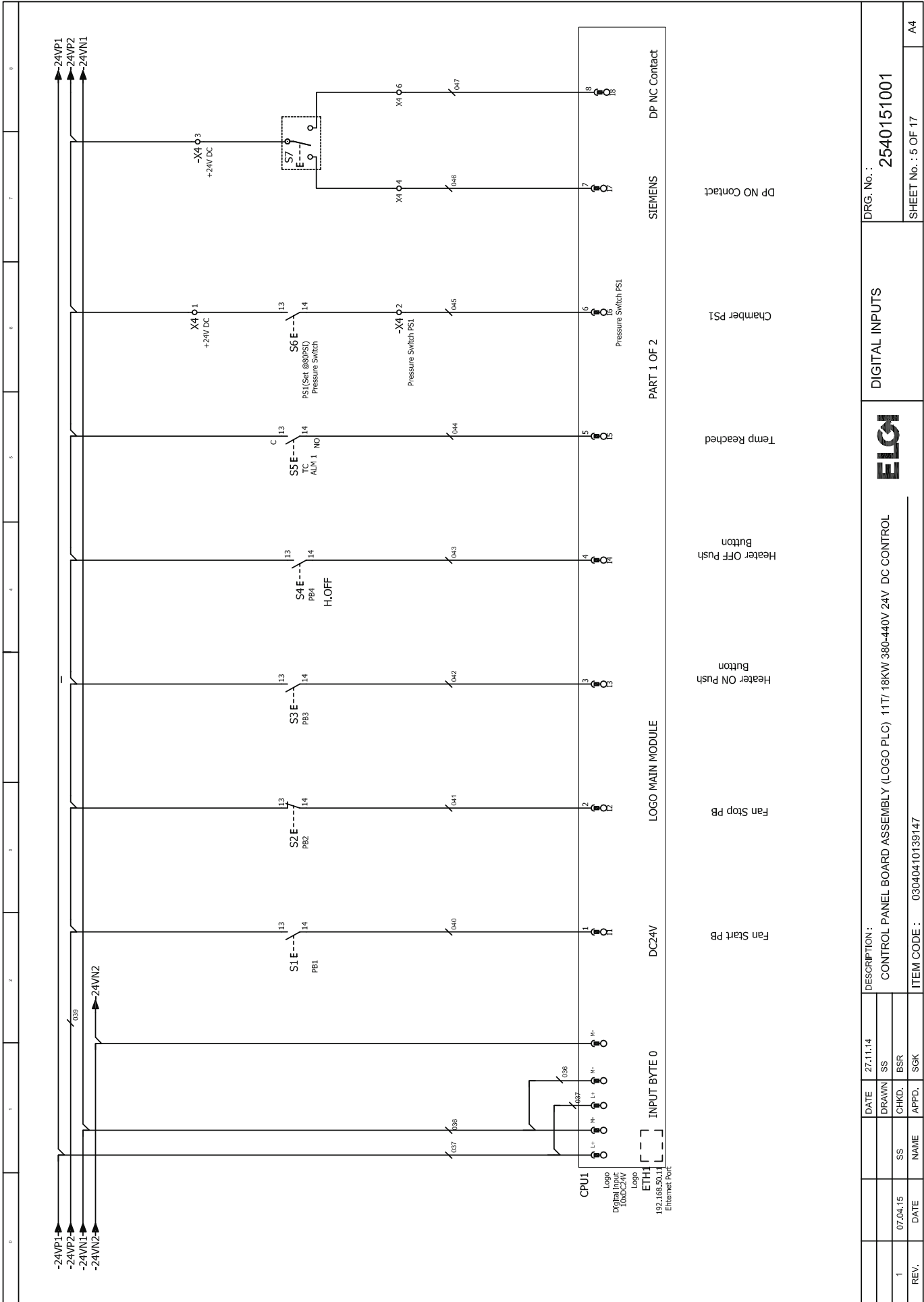

DATE		27.11.14	DESCRIPTION:		DIGITAL INPUTS		DRG. No. :		2540151001	
1	07.04.15	SS	SS	CONTROL PANEL BOARD ASSEMBLY (LOGO PLC) 11T/ 18KW 380-440V 24V DC CONTROL	ELGI		SHEET No. : 5 OF 17		A4	
REV.	DATE	NAME	APPD.	SGK	ITEM CODE :		03040410139147			

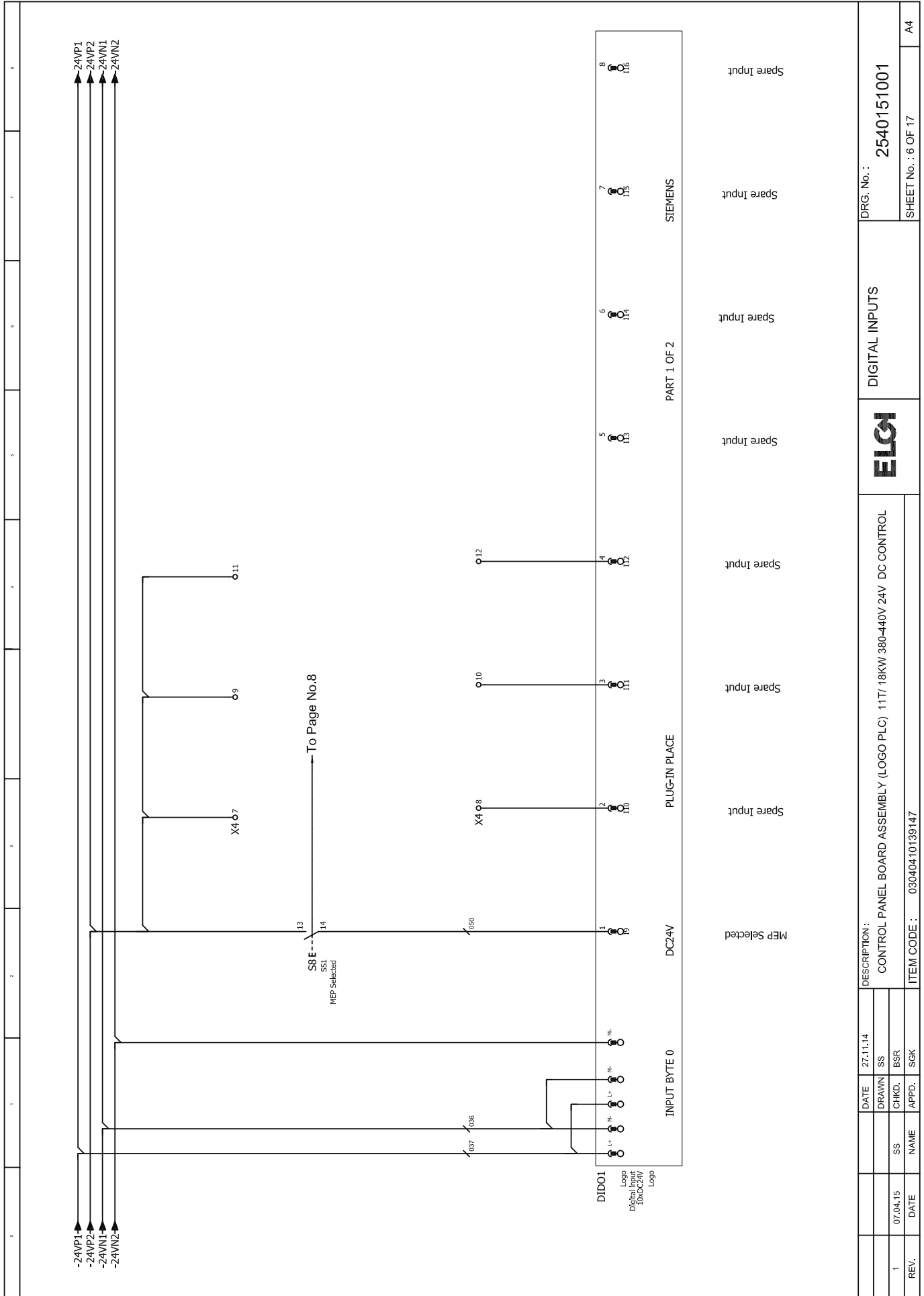

DATE		27.11.14	DESCRIPTION :		DIGITAL INPUTS		DRG. No. :		2540151001
DRAWN		SS	CONTROL PANEL BOARD ASSEMBLY (LOGO PLC) 11T/ 18KW 380-440V 24V DC CONTROL		ELGI		SHEET No. :		6 OF 17
SS		SS	ITEM CODE :		03040410139147		A4		
REV.	DATE	NAME	APPD.	SGK					
1	07.04.15	SS	BSR						

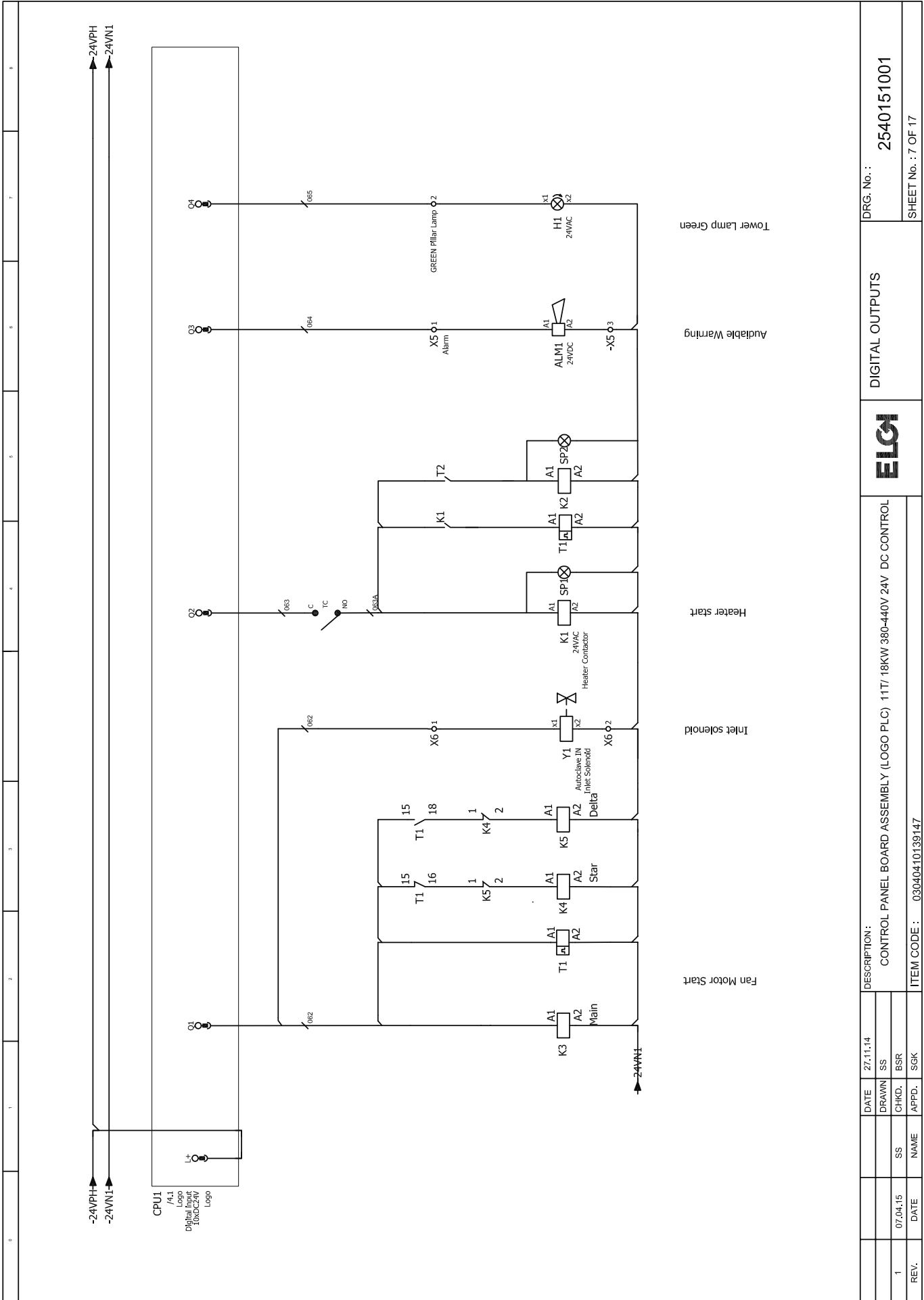

DATE		27.11.14	DESCRIPTION :		CONTROL PANEL BOARD ASSEMBLY (LOGO PLC) 11T/ 18KW 380-440V 24V DC CONTROL	
DRAWN		SS	ELGI		DIGITAL OUTPUTS	
CHKD.		BSR	DRG. No. :		2540151001	
APPD.		SS	SHEET No. :		7 OF 17	
NAME		SS	ITEM CODE :		03040410139147	
DATE		07.04.15				
REV.		1				

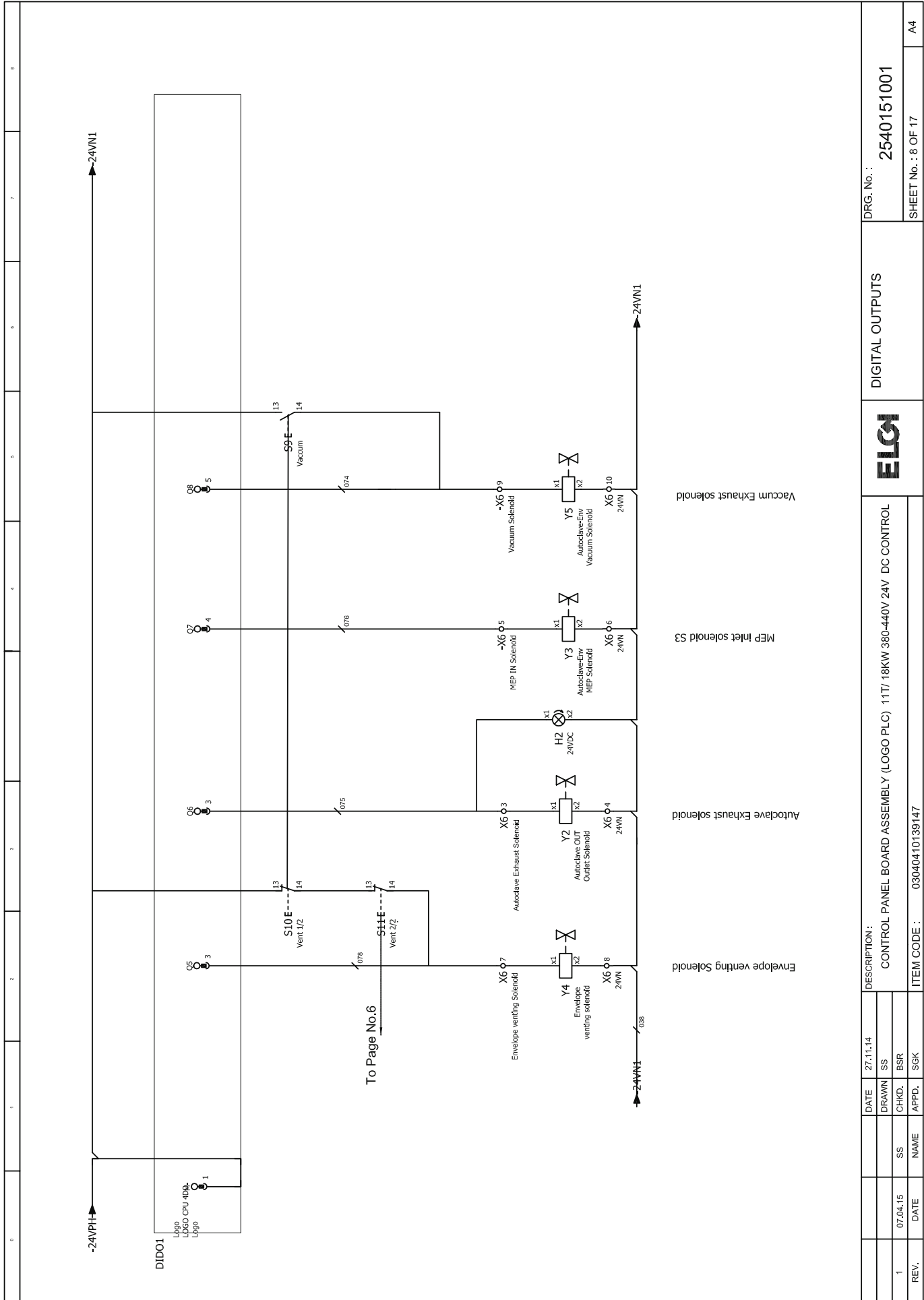

DATE		27.11.14	DESCRIPTION:		CONTROL PANEL BOARD ASSEMBLY (LOGO PLC) 11T/ 18KW 380-440V 24V DC CONTROL		DRG. No. :		2540151001	
DRAWN		SS	ITEM CODE :		03040410139147		DIGITAL OUTPUTS		ELGI	
CHKD.		BSR	REVISION:				SHEET No. :		8 OF 17	
APPD.		SGK	REV.		1		A4			

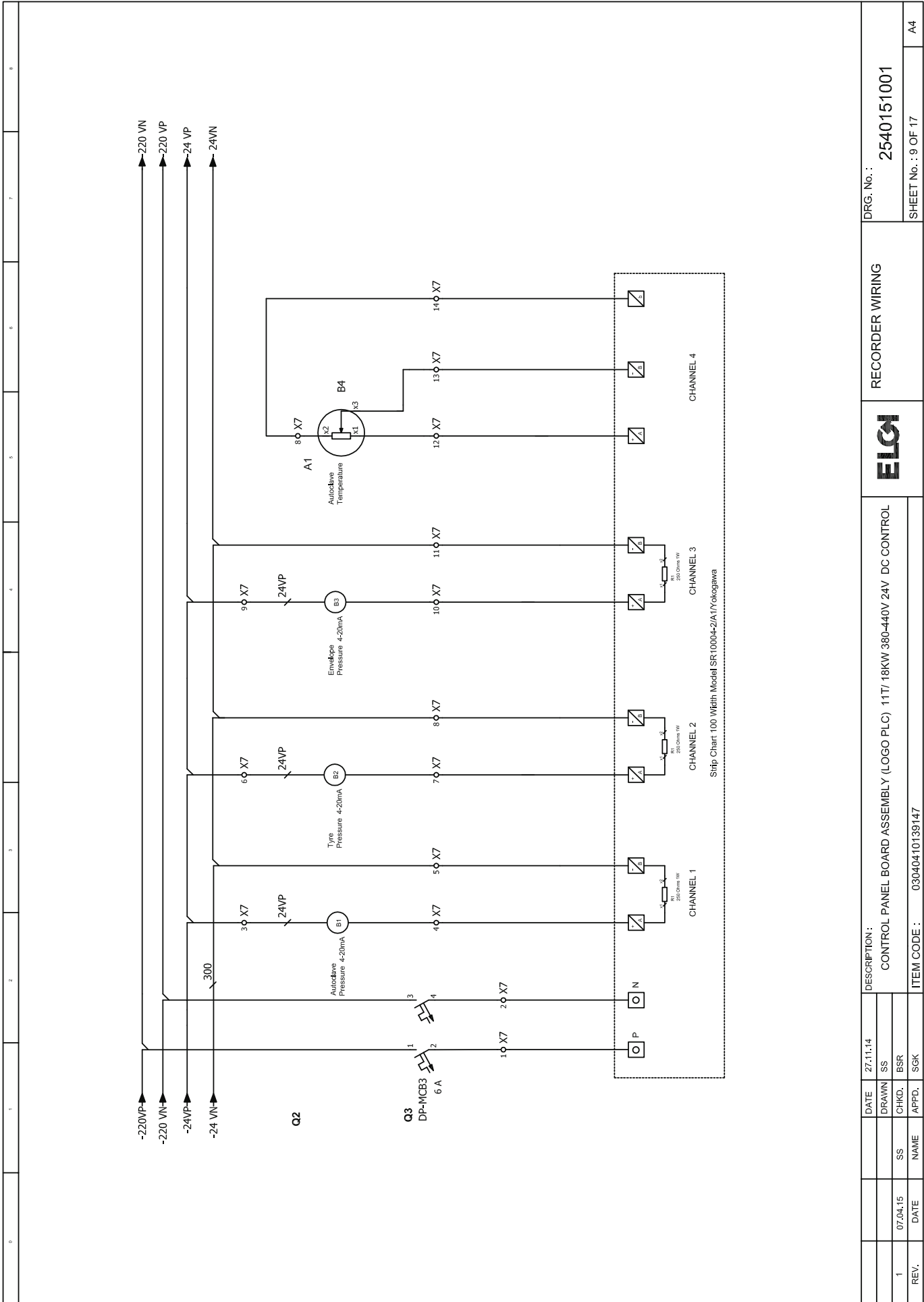

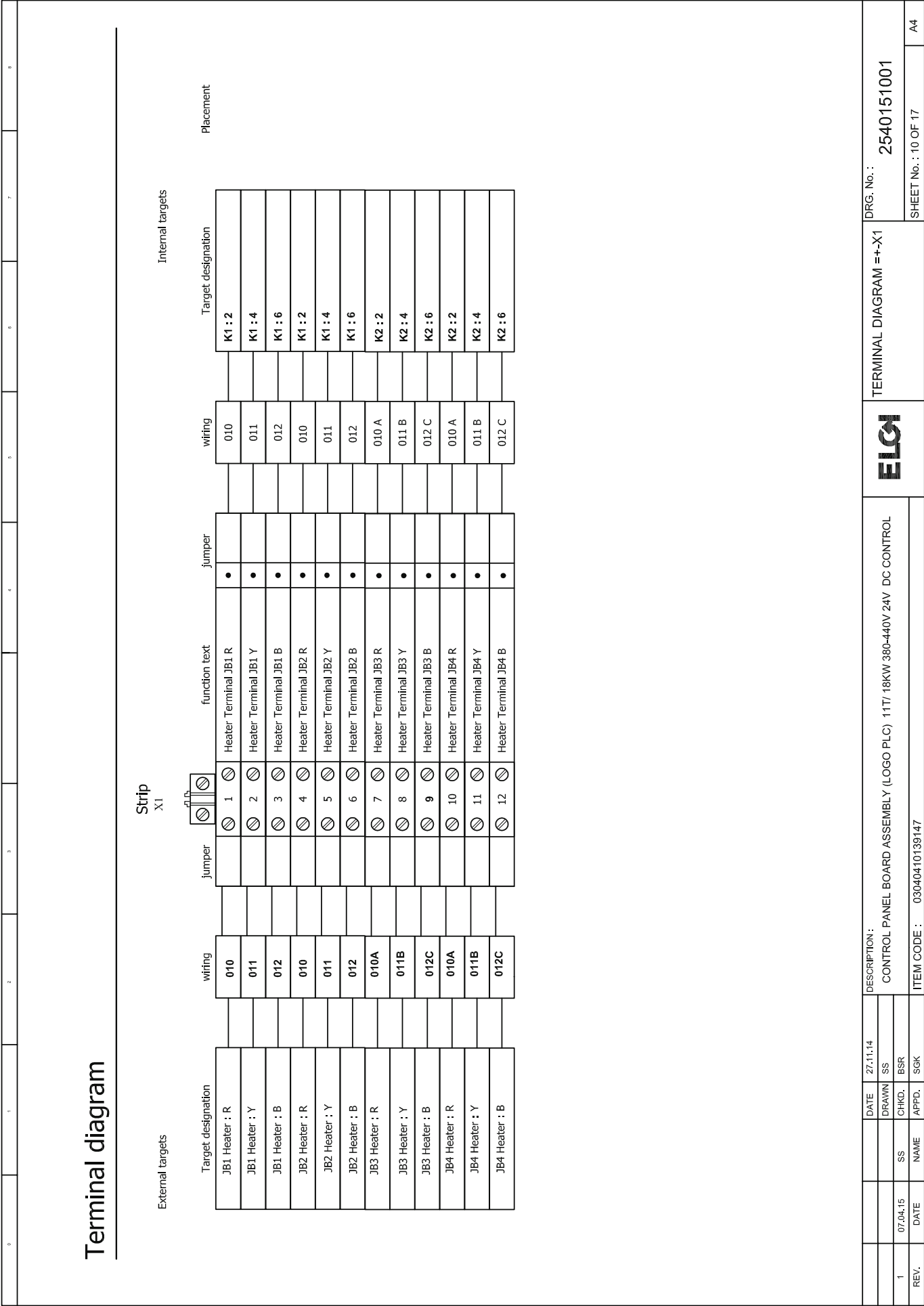

	DATE	27.11.14	DESCRIPTION:	CONTROL PANEL BOARD ASSEMBLY (LOGO PLC) 11T/ 18KW 380-440V 24V DC CONTROL
	DRAWN	SS		
	CHKD.	BSR		
1	DATE		ITEM CODE :	03040410139147
	NAME		ELGI	
	APPD.		TERMINAL DIAGRAM ==X1	
			DRG. No. : 2540151001	
			SHEET No. : 10 OF 17	
			A4	

Terminal diagram - X2

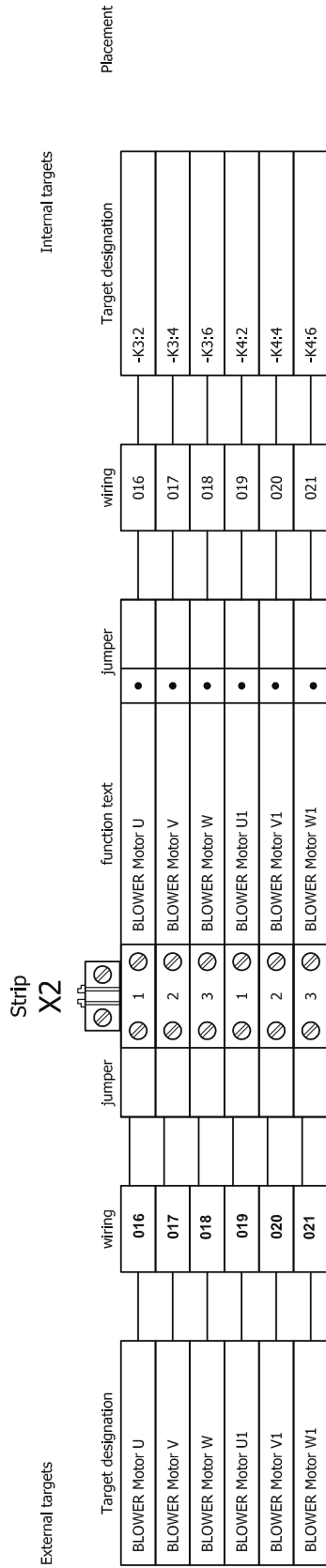

DATE	27.11.14	DESCRIPTION:	CONTROL PANEL BOARD ASSEMBLY (LOGO PLC) 11T/ 18KW 380-440V 24V DC CONTROL
DRAWN	SS	ITEM CODE :	03040410139147
CHKD.	BSR	DRG. No. :	2540151001
SS		SHEET No. :	11 OF 17
NAME			A4
APPD.	SGK		
REV.	1	07.04.15	

Terminal diagram - X3

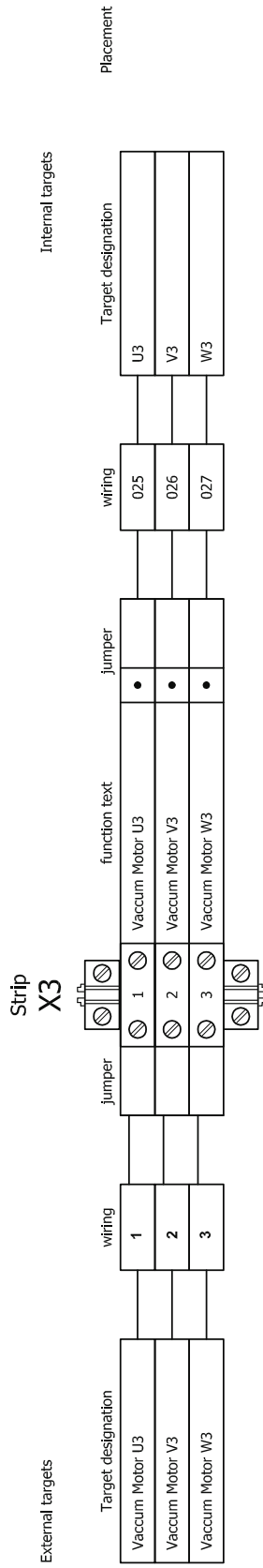

DATE	27.11.14	DESCRIPTION:	CONTROL PANEL BOARD ASSEMBLY (LOGO PLC) 11T/ 18KW 380-440V 24V DC CONTROL
DRAWN	SS		
CHKD.	BSR		
REV.	1	SS	
DATE		NAME	
		APPD.	SGK
		ITEM CODE :	03040410139147
		ELGI	
		DRG. No. :	2540151001
		SHEET No. : 12 OF 17	
		A4	

Terminal diagram - X4

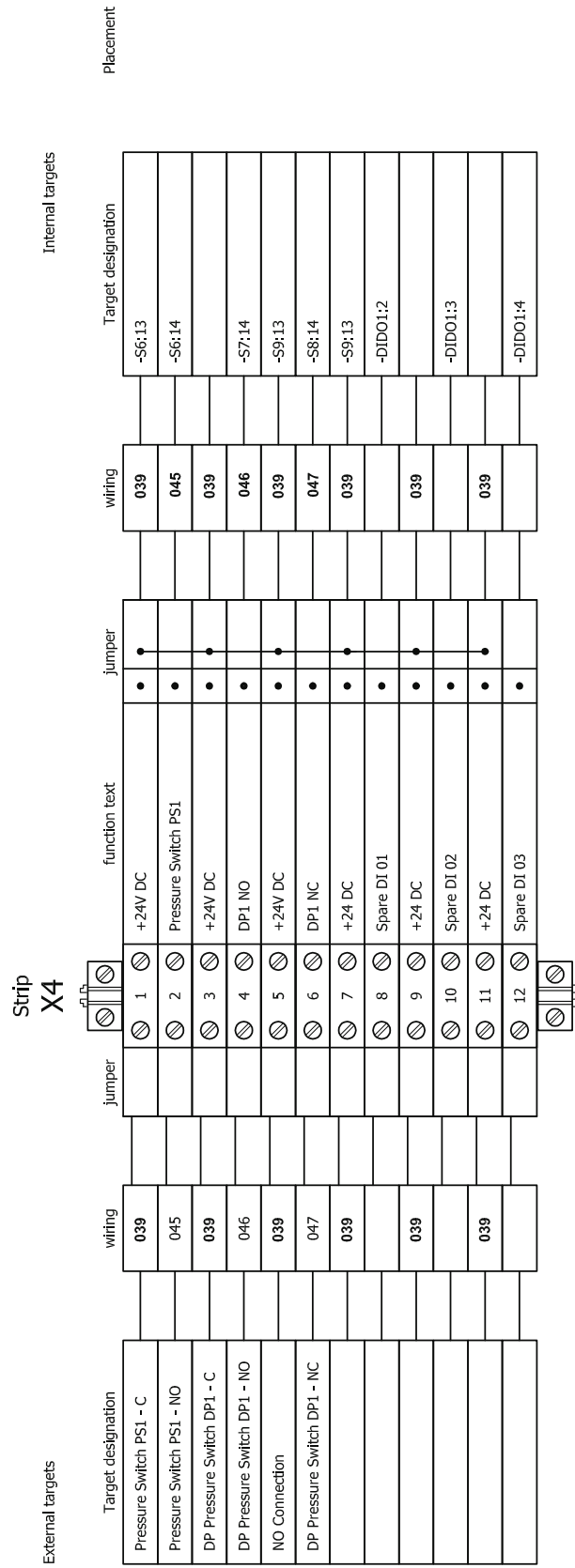

DATE	27.11.14	DESCRIPTION:	CONTROL PANEL BOARD ASSEMBLY (LOGO PLC) 11T/ 18KW 380-440V 24V DC CONTROL
DRAWN	SS	ITEM CODE:	03040410139147
CHKD.	BSR		
SS	SS		
DATE	07/04/15	TERMINAL DIAGRAM =+X4	
NAME	SS	DRG. No. : 2540151001	
APPD.	SGK	SHEET No. : 13 OF 17	
REV.	1	A4	

Terminal diagram - X5

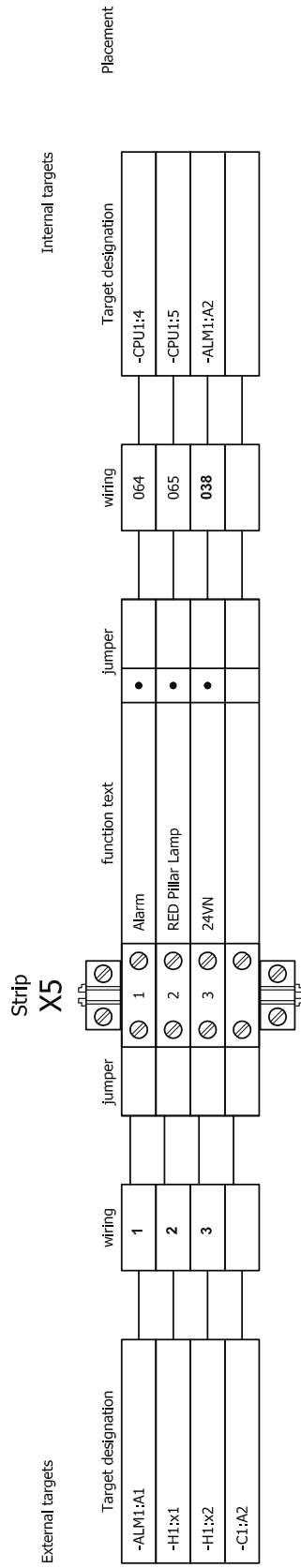

DESCRIPTION:				CONTROL PANEL BOARD ASSEMBLY (LOGO PLC) 11T/ 18KW 380-440V 24V DC CONTROL			
DATE	27.11.14	DRAWN	SS				
REV.	07.04.15	SS	CHKD.	BSR			
	DATE	NAME	APPD.	SGK			
				ITEM CODE : 03040410139147			
				ELGI			
				TERMINAL DIAGRAM ==X5			
				DRG. No. : 2540151001			
				SHEET No. : 14 OF 17			
				A4			

Terminal diagram - X6

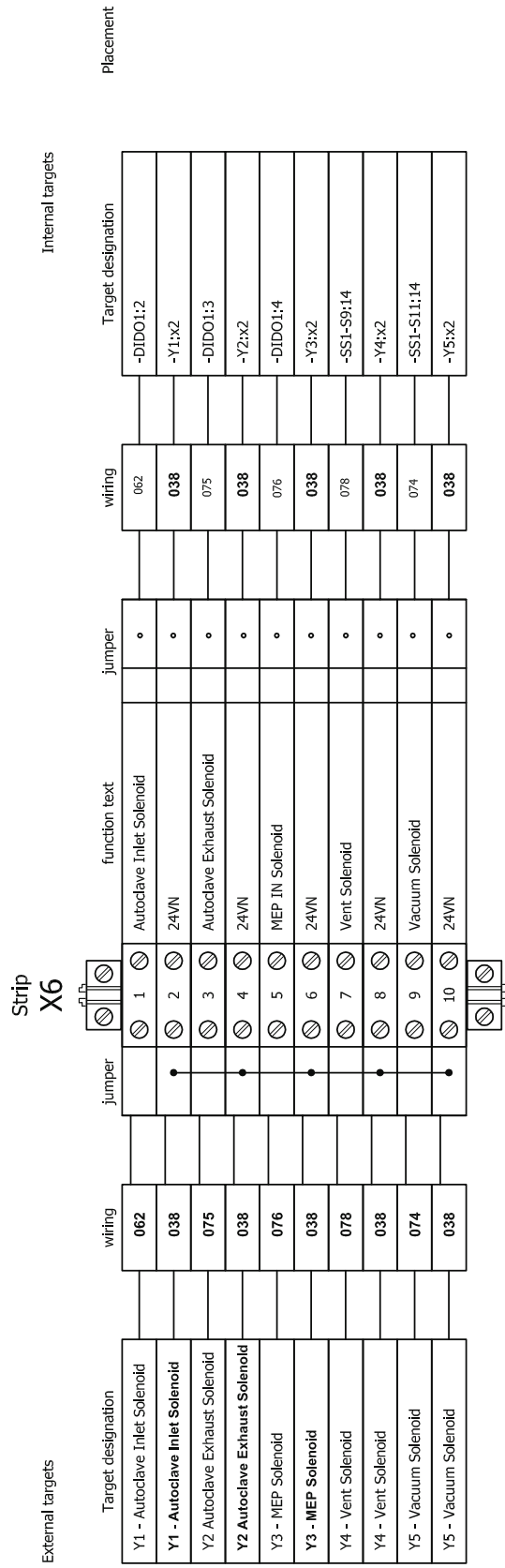

DATE	27.11.14	DESCRIPTION:	CONTROL PANEL BOARD ASSEMBLY (LOGO PLC) 11T/ 18KW 380-440V 24V DC CONTROL	DRG. No. :	2540151001
DRAWN	SS	ITEM CODE :	03040410139147	SHEET No. :	15 OF 17
CHKD.	BSR				
REV.	DATE	NAME	APPD.	SGK	A4

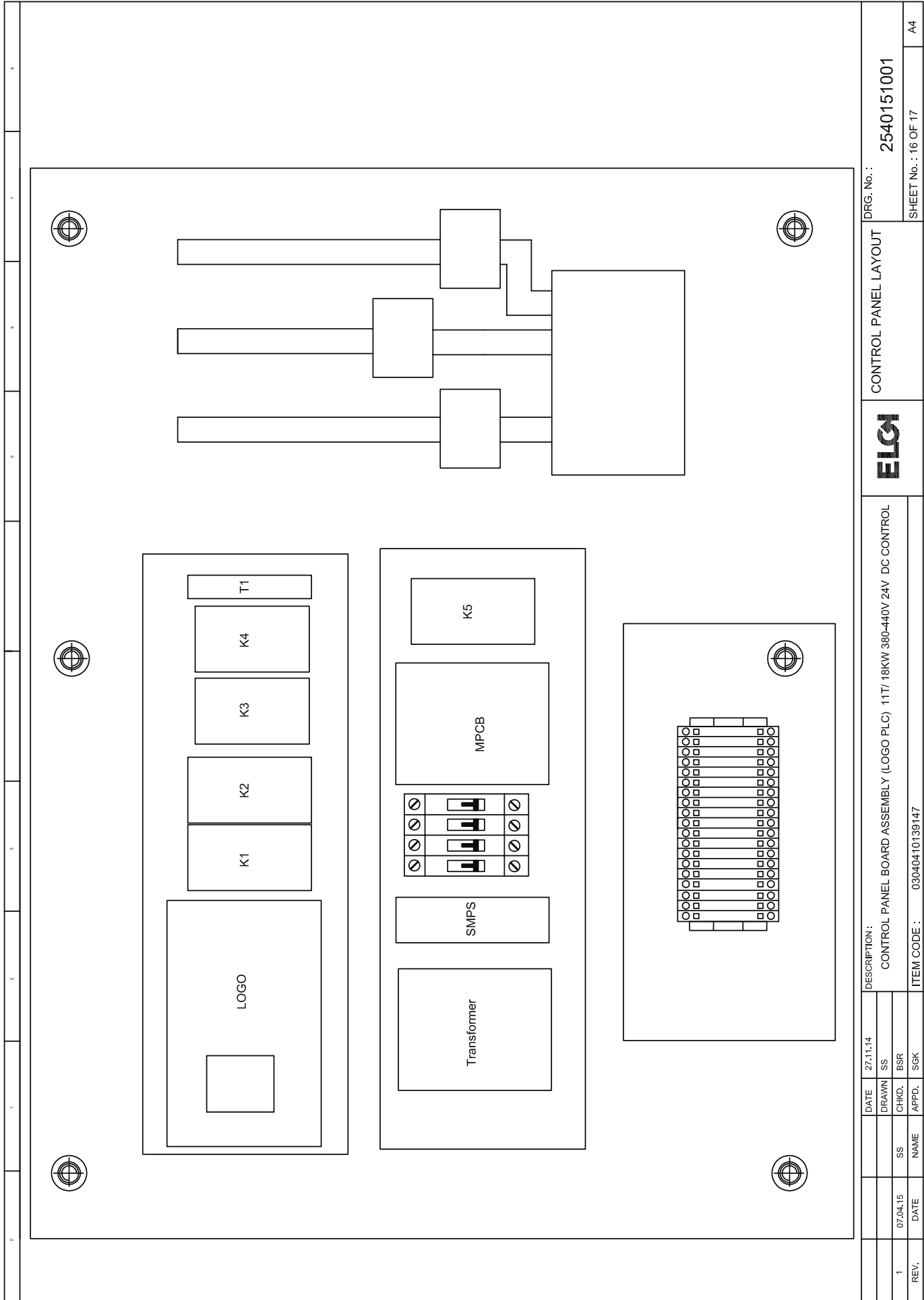

DATE		27.11.14	DESCRIPTION:		DRG. No. :		2540151001		
1	07.04.15	SS	SS	CONTROL PANEL BOARD ASSEMBLY (LOGO PLC) 11T/ 18KW 380-440V 24V DC CONTROL		CONTROL PANEL LAYOUT		SHEET No. : 16 OF 17	
REV.	DATE	NAME	APPD.	SGK	ITEM CODE :	ELGI		A4	
					03040410139147				

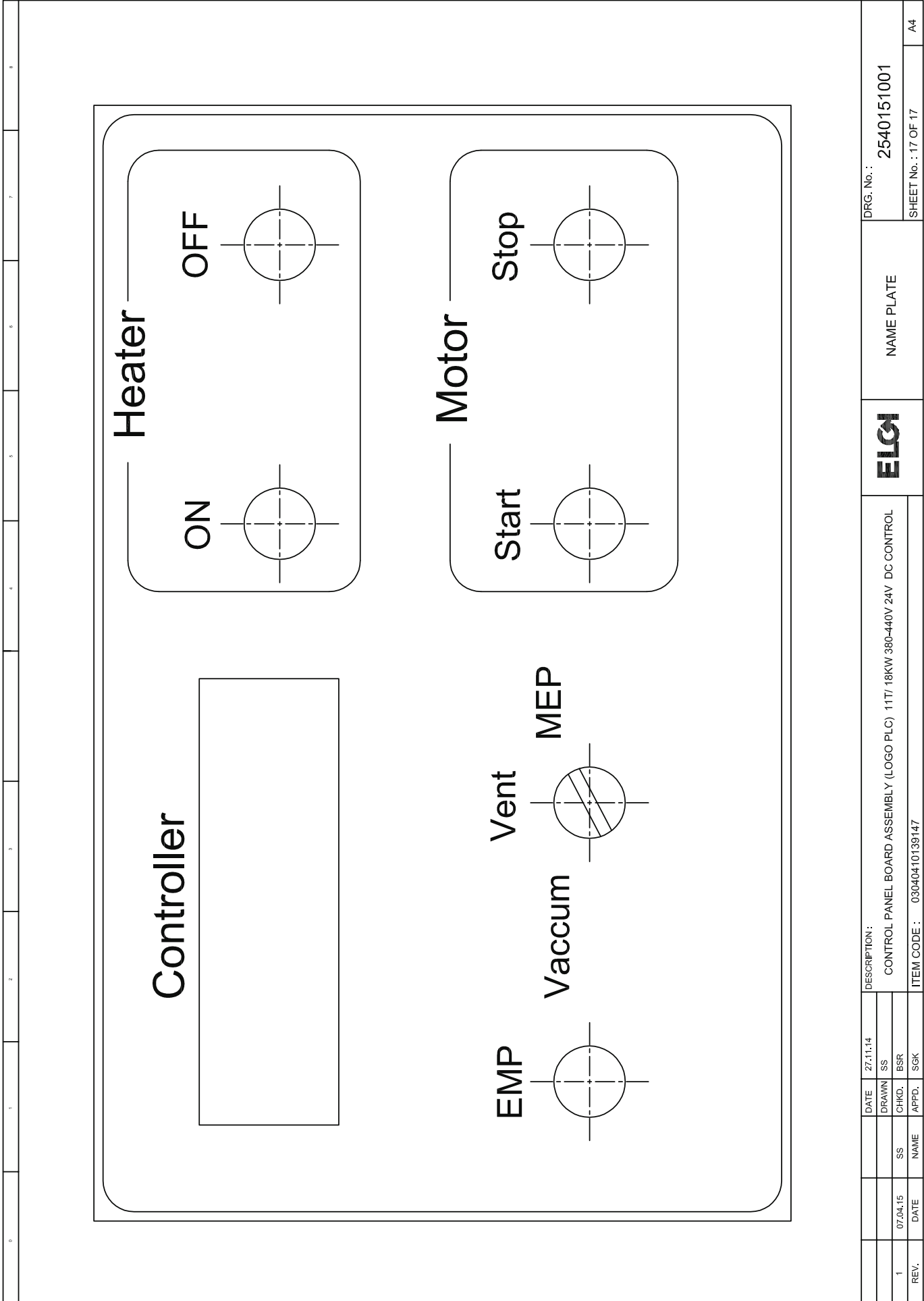

DATE		27.11.14	DESCRIPTION:		DRG. No. : 2540151001	
DRAWN		SS	CONTROL PANEL BOARD ASSEMBLY (LOGO PLC) 11T/18KW 380-440V 24V DC CONTROL		NAME PLATE	
CHKD.		BSR	ITEM CODE : 03040410139147		SHEET No. : 17 OF 17	
REV.		DATE	NAME	APPD.	SGK	A4

11 Pneumatic Circuit

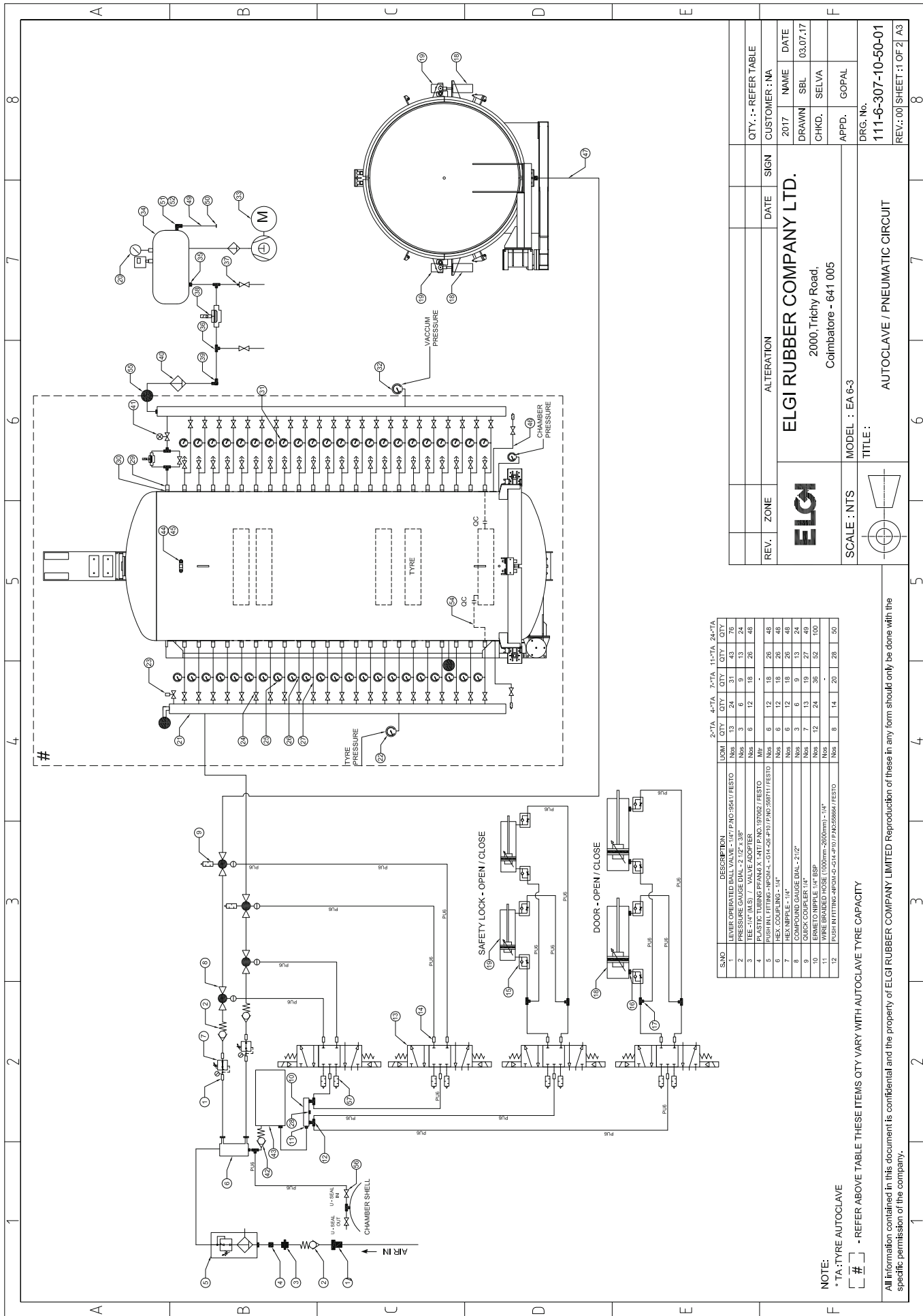

S/NO	DESCRIPTION	2-TA	4-TA	7-TA	11-TA	24-TA
1	LEVER OPERATED BALL VALVE - 1/2" P.ND:35417 / FESTO	Nos	13	24	31	43
2	PRESSURE SWITCH - 1/2" P.ND:35417 / FESTO	Nos	3	6	12	18
3	1/2" x 1/4" BALL VALVE ADAPTER	Nos	6	12	18	26
4	PLASTIC TUBING PFANUCX - 1/4" P.ND:197682 / FESTO	Mtr	6	12	18	26
5	PUSH BALL FITTING - P.ND:414 - 1/4" x 1/8" P.ND:280711 / FESTO	Nos	6	12	18	26
6	HEX. COUPLING - 1/4"	Nos	6	12	18	26
7	HEX. NIPPLE - 1/4"	Nos	6	12	18	26
8	CONDUIT GAUGE DIA. - 27/32"	Nos	3	6	9	13
9	CONDUIT GAUGE DIA. - 1/2"	Nos	3	6	9	13
10	LEGNETO NIPPLE 1/4" BSP	Nos	12	24	36	52
11	WIRE BRAIDED HOSE (1000mm 26500mm) - 1/4"	Nos	8	14	20	28
12	PUSH FITTING - P.ND:314 - 1/4" x 1/8" P.ND:59884 / FESTO	Nos	8	14	20	28

NOTE:
 * TA: TYRE AUTOCLAVE
 [#] - REFER ABOVE TABLE THESE ITEMS QTY VARY WITH AUTOCLAVE TYRE CAPACITY

All information contained in this document is confidential and the property of ELGI RUBBER COMPANY LIMITED. Reproduction of these in any form should only be done with the specific permission of the company.

REV.	ZONE	ALTERATION	DATE	SIGN	QTY. :- REFER TABLE
					CUSTOMER : NA
					CUSTOMER : NA
					2017 NAME DATE
					DRAWN SBL 03.07.17
					CHKD. SELVA
					APPD. GOPAL
					DRG. No.
					111-6-307-10-50-01
					REV.: 00 SHEET : 1 OF 2 A3



SCALE : NTS
 MODEL : EA 6-3

TITLE :

AUTOCLAVE / PNEUMATIC CIRCUIT

ELGI RUBBER COMPANY LTD.
 2000, Trichy Road,
 Coimbatore - 641 005

S. No.	Description	UOM	Qty.	
1	REDUCER NIPPLE (CONE SEATING) - 3/4" x 1/2"	NOS	5	
2	NON RETURN VALVE 3/4"	NOS	3	
3	HEX NIPPLE - 3/4"	NOS	4	
4	ELBOW - 3/4"	NOS	2	
5	AIR FILTER CUM REGULATOR-1/2"-D-MIDI / P.NO:159584 / FESTO	NOS	1	
6	MANIFOLD – Ø 90 x325	NOS	1	
7	REGULATOR -1/2" / P.NO : 159625 / FESTO	NOS	2	
8	BALL VALVE -3/4" / W6612E20 CF8 S4 T ONF BSP / AVCON	NOS	4	
9	SILENCER UC - 3/4" / P.NO :2311 / FESTO	NOS	4	
10	MANIFOLD FR-4-1/4 -C/P.NO.7849 / FESTO	NOS	2	
11	PUSH IN FITTING -NPQM -D -G14 -P10 / P.NO:558664 / FESTO	NOS	-	#
12	PUSH IN FITTING - NPQM -7 -G14 -Q6 -P10 / P.NO:558739 / FESTO	NOS	2	
13	SOLENOID OPERATED VALVE 5/3" / P.NO : DS265SC61/JANATICS	NOS	4	
14	PUSH IN L FITTING - NPQM -L - G14 -Q6 -P10 / P.NO :558711 / FESTO	NOS	-	#
15	FLOW CONTROL VALVE 1/4" x PU6	NOS	8	
16	BUSH NUT 1/2" x 1/4"	NOS	4	
17	UNION TEE 1/4" x PU6 / P.NO :WP2300606 / JANATICS	NOS	4	
18	PNEUMATIC CYLINDER %%c100 200 - PPV / P.NO :163486 / FESTO	NOS	2	
19	PNEU . CYLINDER DSBC %%c50 25 -PPV -A -N3 / P.NO :1366948 / FESTO	NOS	2	
20	VACCUM GAUGE DIAL- 4" X 3/8"	NOS	1	
21	HEADER (TYRE PRESSURE)	NOS	2	
22	PRESSURE GAUGE DIAL - 4" x 3/8"	NOS	2	
23	SAFETY VALVE - 3/4" /125PSI	NOS	1	
24	LEVER OPERATED BALL VALVE -1/4" / P.NO :9541/ FESTO	NOS	-	#
25	PRESSURE GAUGE DIAL - 2 1/2" x 1/4"	NOS	-	#
26	TEE -1/4" (M.S) / VALVE ADOPTER	NOS	-	#
27	PLASTIC TUBING PFAN-6 X 1-NT/ P.NO.197062 / FESTO	MTR	-	#
28	DUMMY – 1/4"	NOS	1	
29	HEX .COUPLING – 1/4"	NOS	-	#
30	HEX NIPPLE - 1/4"	NOS	-	#
31	COMPOUND GAUGE DIAL – 2 1/2"	NOS	-	#
32	COMPOUND GAUGE DIAL - 4" x 3/8"	NOS	1	
33	VACCUM PUMP / TMS-15 / 1 HP / 1440 RPM / TOSHNIVAL	NOS	1	
34	VACCUM PUMP TANK	NOS	1	
35	REDUCER NIPPLE - 3/4" x 1/2"	NOS	1	
36	TEE -1/2" (M.S)	NOS	2	
37	REDUCER NIPPLE - 3/4" x 1/4"	NOS	1	
38	AVCON VALVE -1/2" / P.NO :9230	NOS	1	
39	ELBOW -1/2" (M.S)	NOS	1	
40	AIR FILTER 1/2" / F1563 3 /JANATICS	NOS	1	
41	NEEDLE VALVE -1/4"	NOS	1	
42	NON RETURN VALVE 1/4"	NOS	1	
43	ACCUMULATOR – Ø 90 x700mm	NOS	1	
44	SAFETY VALVE - 3/4" x 90PSI	NOS	2	
45	TEE 3/4" (MS)	NOS	1	
46	HP HOSE 3/4" – 600mm	MTR/NOS	3	
47	HP RUBBER HOSE 3/4" – 1200mm	MTR/NOS	1	
48	HP RUBBER HOSE 1/2" – 750mm	MTR/NOS	2	
49	HP RUBBER HOSE 1/4"	MTR/NOS	-	#
50	QUICK COUPLER 1/4"	NOS	-	#
51	HOSE CONNECTOR - 1/4"	NOS	2	
52	HOSE CLIP - 1/4"	NOS	2	
53	ERMETO NIPPLE 1/4" BSP	NOS	-	#
54	WIRE BRAIDED HOSE (1000mm TO 2600mm) - 1/4"	MTR	-	#
55	TRANSMITTER (TYRE / CHAMBER & VACCUM PRESSURE) 0-16 BAR	NOS	3	
56	MINILEX BALL VALVE – 1/4"	NOS	2	
57	SILENCER (CONICAL) - 1/4" / P.NO:ASC0161/ JANATICS	NOS	8	

Note: The quantity varies for the components for which the '#' symbol is added. Kindly refer drawing.

12 Parts List

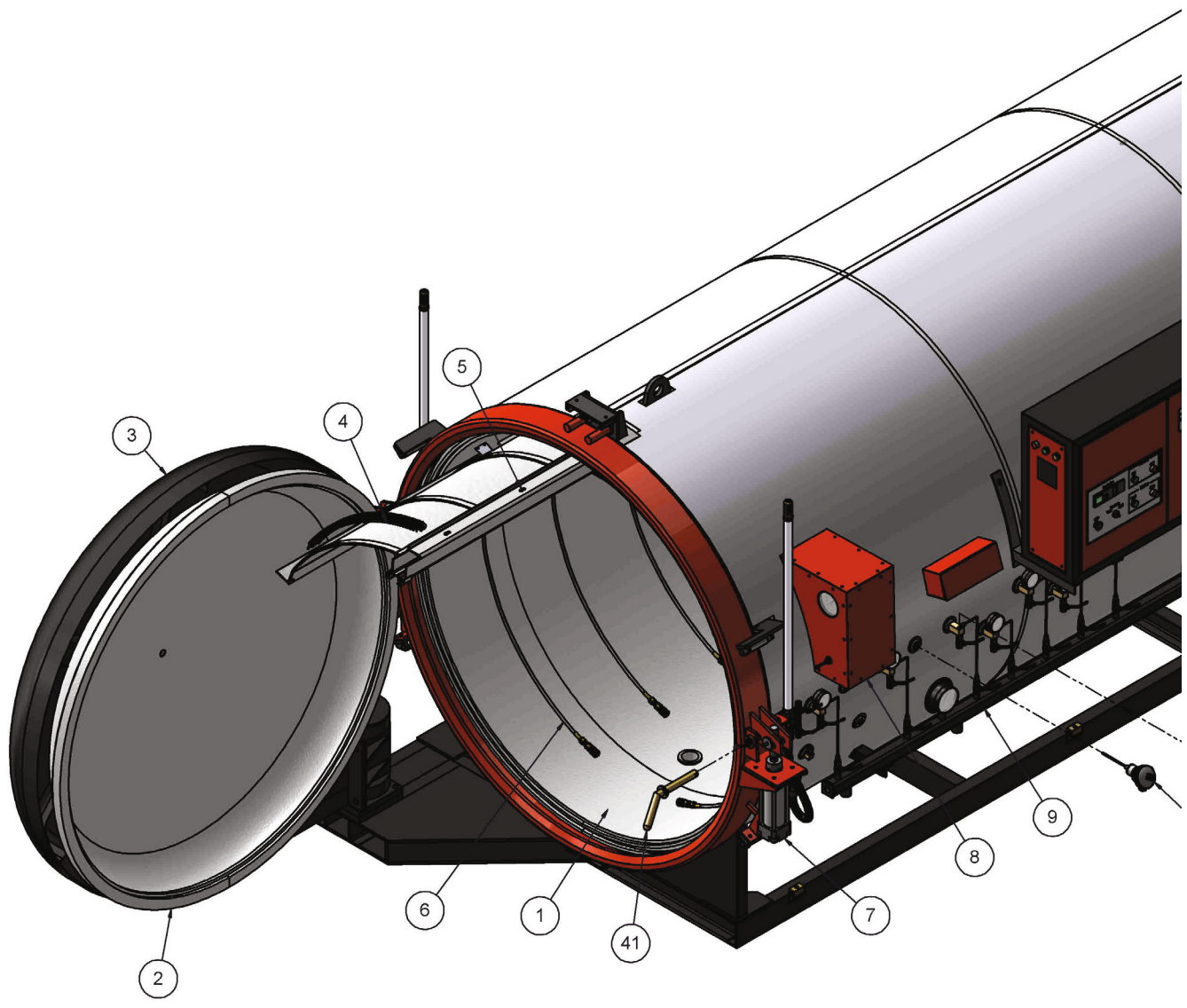

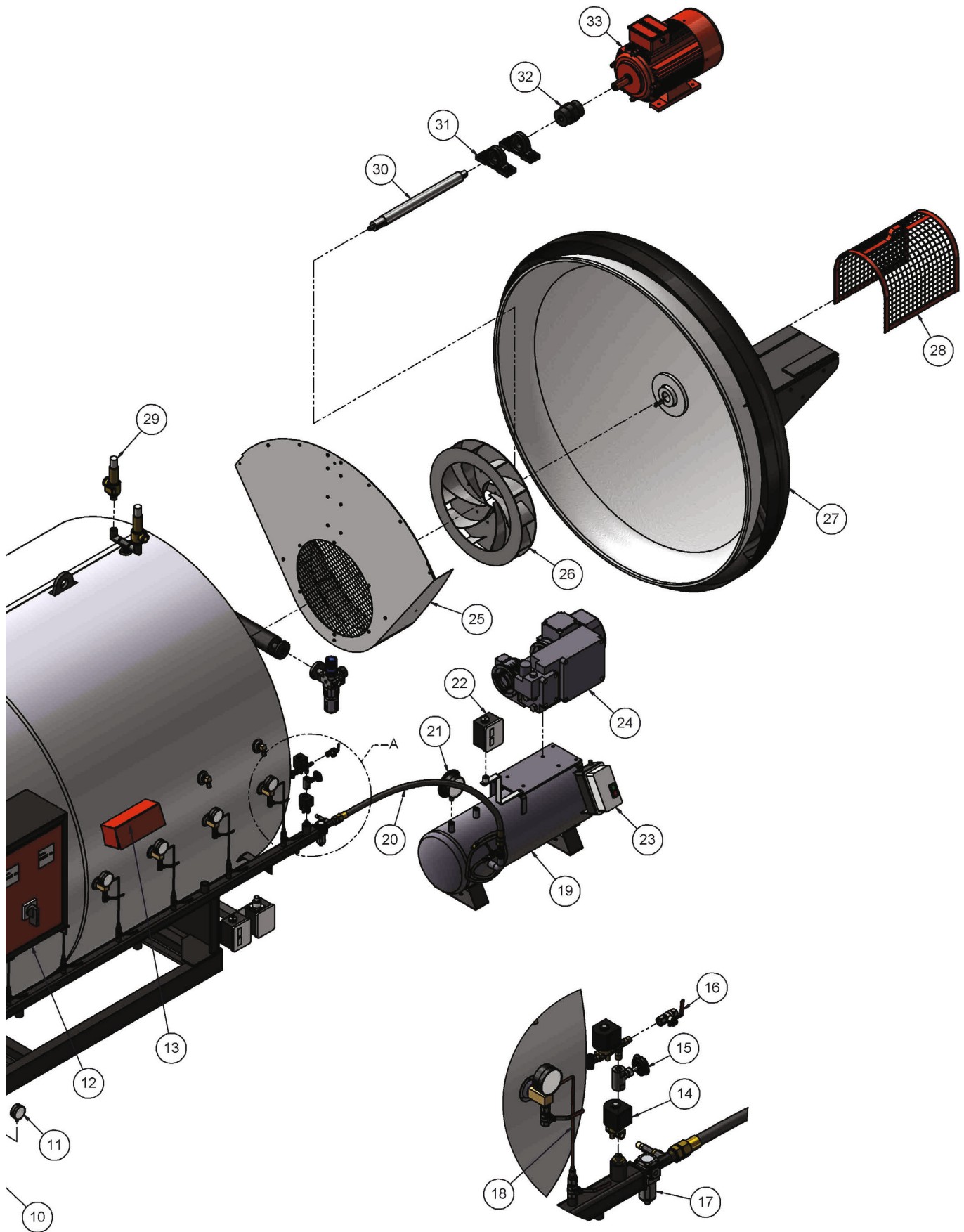

DETAIL A

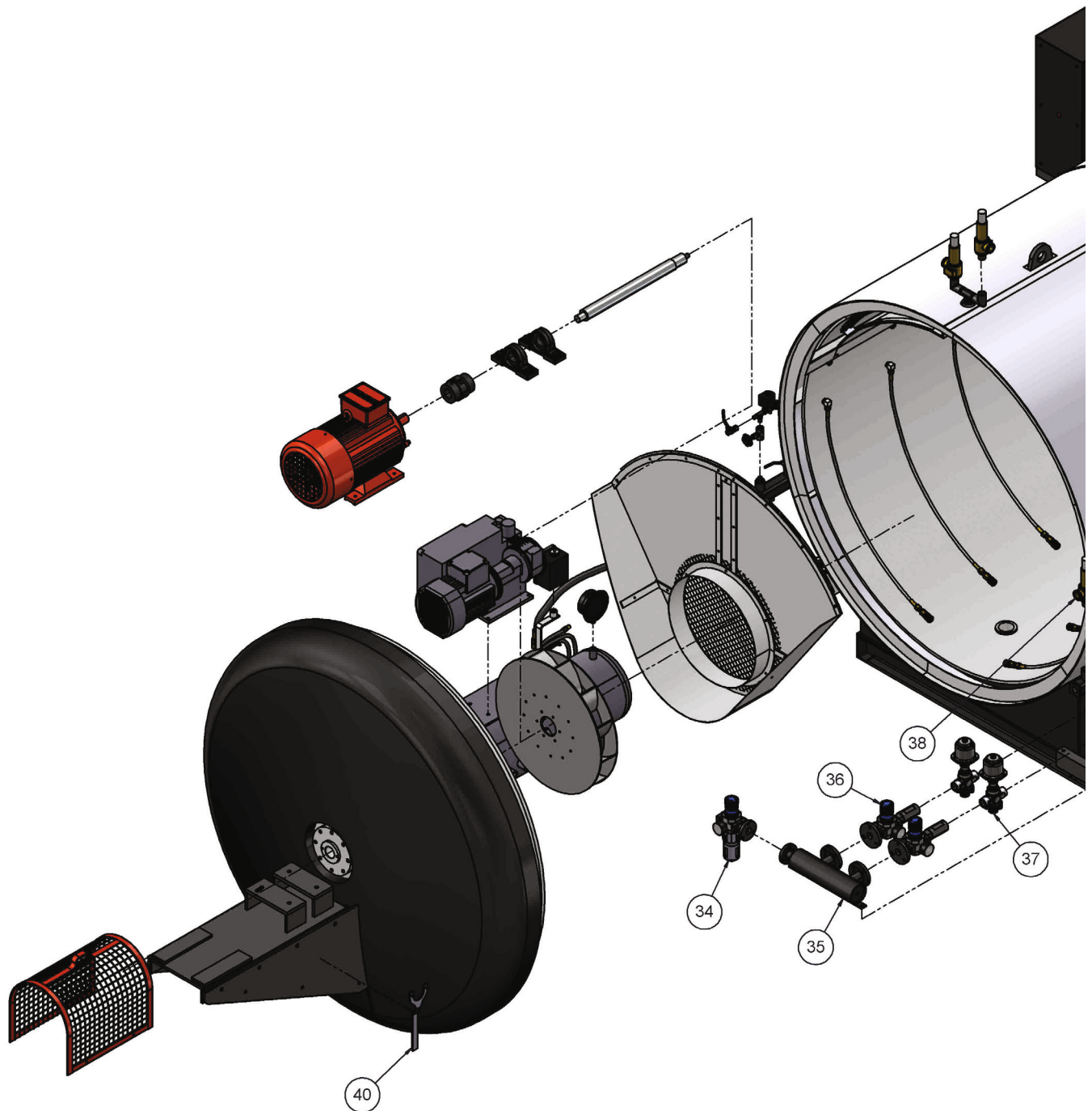

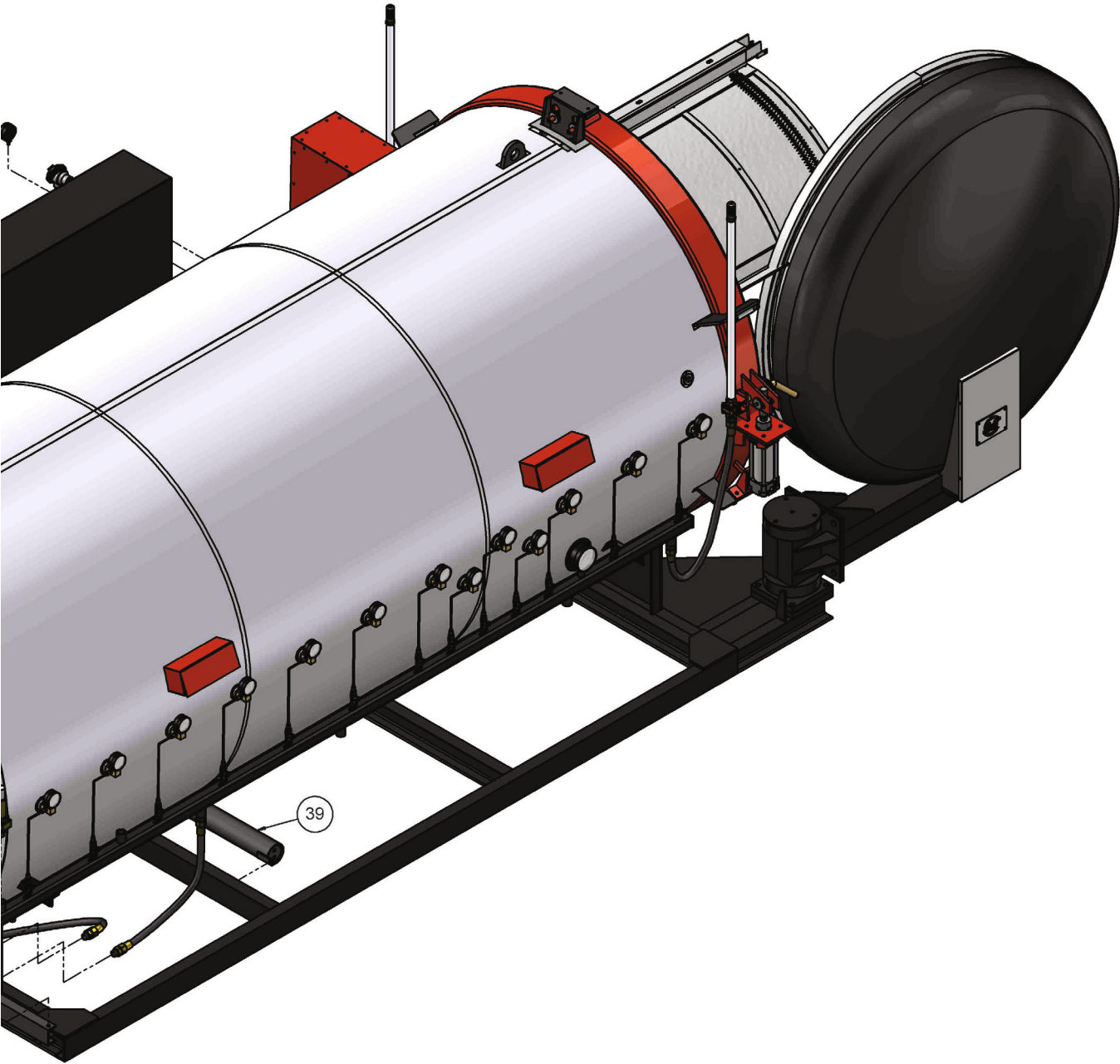

Parts List - BOM

S. no.	Order Code	Description	UOM	Qty
1	MC5663/1	CHAMBER FRAME WITH SHELL	NOS	1
2	MC5663/2	DISH END	NOS	2
3	MC5663/3	FRP COVER BLACK - FRONT	NOS	1
4	MC5663/4	FINNED HEATER 1.5KW	NOS	24
5	MC5663/5	STRAIGHT RAIL INNER 5mm THK - 4MTR	NOS	1
6	MC5663/6	WIRE BRAIDED HOSE	NOS	26
7	MC5663/7	PNEUMATIC CYLINDER	NOS	2
8	MC5663/8	RECORDER FRAME	NOS	1
9	MC5663/9	HEADER TYRE	NOS	2
10	MC5663/10	PT100-8211-RH002S-W3-A3-2-ABP14-6-115-C-2TTS/RADIX	NOS	1
11	MC5663/11	PRESSURE GAUGE 0 TO 150 PSI 2.1/2"	NOS	13
12	MC5663/12	CONTROL PANEL ASSEMBLY AUTOINFL 11 T	NOS	1
13	MC5663/13	ADAPTOR TERMINAL	NOS	12
14	MC5663/14	SOL. VALVE 1/4"NC / AVCON	NOS	2
15	MC5663/15	NEEDLE VALVE (SS) 1/4"	NOS	1
16	MC5663/16	BALL VALVE 1/4"	NOS	45
17	MC5663/17	AIR FILTER 1/2"	NOS	1
18	MC5663/18	BUNDY TUBE	MTR	35.7
19	MC5663/19	TANK (MS) LTS-EC MEP	NOS	1
20	MC5663/20	RUBBER HOSE HP 3/4"	NOS	1
21	MC5663/21	PRESSURE GAUGE 0 TO 150 PSI 4" DIAL	NOS	2
22	MC5663/22	PRESSURE SWITCH - 1 TO 0 BAR / DANFOSS	NOS	1
23	MC5663/23	STARTER DOL 0.5HP	NOS	1
24	MC5663/24	OIL LUBRICATED VACUUM PUMP	NOS	1
25	MC5663/25	BLOWER FAN DUCT	NOS	1
26	MC5663/26	BLOWER FAN ELECTRIC CHAMBER	NOS	1
27	MC5663/27	FRP COVER BLACK - BACK	NOS	1
28	MC5663/28	BLOWER SHAFT GUARD	NOS	1
29	MC5663/29	SAFETY VALVE 3/4" X 3/4" - 90PSI	NOS	2
30	MC5663/30	FAN SHAFT ELECTRIC CHAMBER	NOS	1
31	MC5663/31	BEARING PILLOW BLOCK	NOS	2
32	MC5663/32	FAN SHAFT LOVE JOY COUPLING	NOS	1
33	MC5663/33	MOTOR 10HP (7.5KW) / 1750 RPM	NOS	1
34	MC5663/34	AIR FILTER CUM REGULATOR	NOS	1
35	MC5663/35	MANIFOLD OD90 X 325L / EC60	NOS	1
36	MC5663/36	REGULATOR 1/2"	NOS	2
37	MC5663/37	PNEUMATIC VALVE 3/2 WAY / AVCON	NOS	2
38	MC5663/38	SAFETY VALVE 3/4" X 3/4" - 125PSI	NOS	1
39	MC5663/39	ACCUMULATOR	NOS	1
40	MC5663/40	C – SPANNER SEALING HUB	NOS	1
41	MC5663/41	SAFETY VALVE HANDLE	NOS	2

13 Essential Spares List

S. No.	Order Code	Description	UOM	Qty.
1	MC5663/ES/1	Seal kit for Pneumatic Cylinder- DNC 100-200 PPV/Festo	Nos	2
2	MC5663/ES/2	Seal kit for Pneumatic Cylinder- DNC 50-50 PPV/Festo	Nos	2
3	MC5663/ES/3	Seal kit for Solenoid operated valve 5/3 x 1/4" /Janatics	Nos	2
4	MC5663/ES/4	Door lock handle	Nos	2
5	MC5663/ES/5	Seal kit for Safety Valve 3/4 " x 3/4" / Ryder	Nos	3
6	MC5663/ES/6	Pressure Gauge 2 1/2 "	Nos	3
7	MC5663/ES/7	Compound Gauge 2 1/2 "	Nos	3
8	MC5663/ES/8	Gland Packing - 8mm	Set	1
9	MC5663/ES/9	U Seal -60"	Nos	2
10	MC5663/ES/10	Sealing Hub	Nos	1
11	MC5663/ES/11	Blower fan shaft`	Nos	1
12	MC5663/ES/12	Love joy coupling	Nos	2
13	MC5663/ES/13	Gland packing PTFE	Set	1
14	MC5663/ES/14	Hinned heater 1.5 kw	Nos	24
15	MC5663/ES/15	Pressure Transmitter S-10/0-6 Bar/4-20MA/DC 10-30V/P-9013539/Wika - BR	Nos	3
16	MC5663/ES/16	Starter DOL 0.5HP/BE1D1735/415 V/306/ Telemech - DOL	Nos	1
17	MC5663/ES/17	Flexible Hose (PVC) ID 20 Steel Wired	Mtr	13
18	MC5663/ES/18	Temperature Controller-Pid / Model:PX4TAY1-1V070(Standard)/Fuji - TC1	Nos	2
19	MC5663/ES/19	PT100-8211-RH002S-W3-A3-2-ABP14-6-115-C-2TTS/Radix	Nos	2
20	MC5663/ES/20	Terminal Block 100A Add Type	Nos	11
21	MC5663/ES/21	Terminal Block End Plate 100A	Nos	4
22	MC5663/ES/22	Diff Pressure Switch - 0.5 To 4 Bar / 3/8 BSP / 017D002166/ Danfoss - S7	Nos	1
23	MC5663/ES/23	Pressure Switch -1 to 10 Bar / 3/8BSP / 017-521566 / Danfoss - S6	Nos	1