

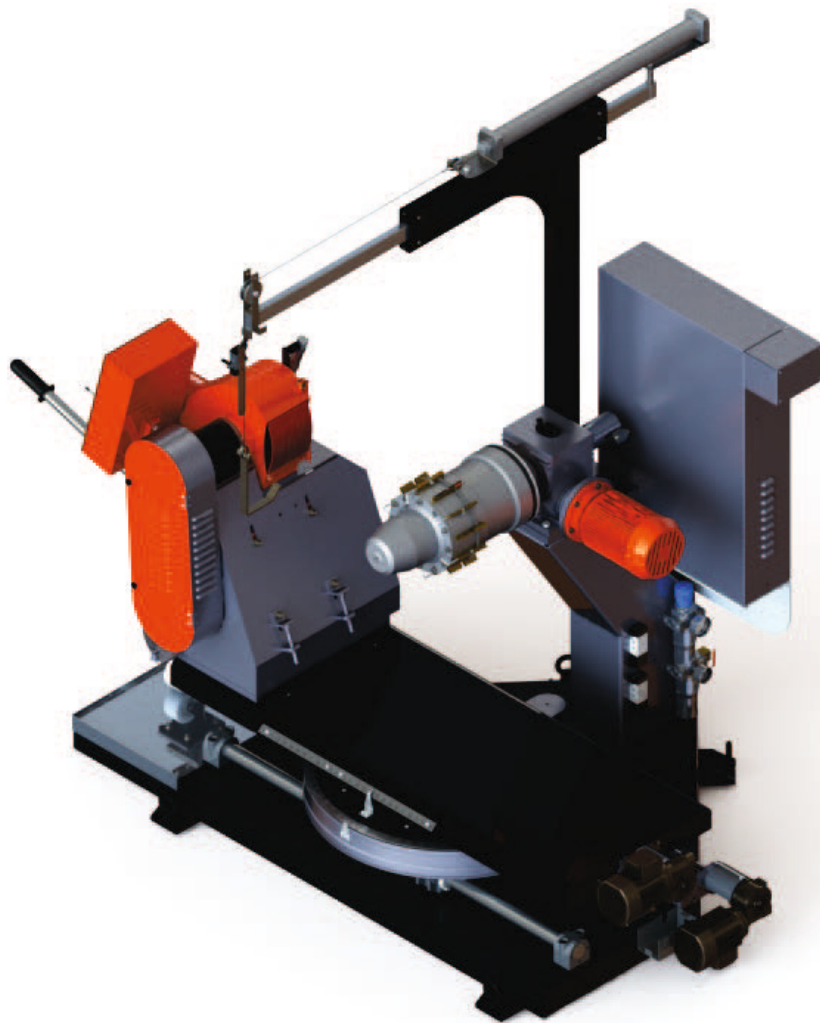

Buffing Machine BF 5D



Instruction Manual

The company reserves the right to change equipment specifications and models without notice. Pictures are representative and may not be part of the standard equipment.

Elgi Rubber Company Limited

2000 Trichy Road • Coimbatore 641 005 • Tamil Nadu • India • +91 (422) 232 1000 • info@in.elgirubber.com • www.elgirubber.com

Foreword

The Buffing Machine BF 5D is a rugged and simple machine for buffing a worn-out tyre in the inflated, road running condition to achieve a perfect, concentric buff profile and the most appropriate buff texture, suitable for retreading or recapping in the precure or mold-cure process.

The machine is designed for buffing a wide range of tyres and the required buffing radius can be achieved by simple adjustments. The machine is designed and manufactured for accurate and trouble-free performance and can be operated by unskilled persons with little training. This instruction manual details installation, commissioning, operation and preventive maintenance procedures.

Contents

01 Description	3
02 Specifications	4
03 Assembly and Commissioning Tools	5
04 Installation and Commissioning	6
05 Pre-Operation Checks	7
06 Operation	8
07 Do's and Don'ts	9
08 Troubleshooting	10
09 Preventive Maintenance	13
10 Electrical Drawings	14
11 Pneumatic Circuit	22
12 Parts List	23

01 Description

The Buffing Machine BF 5D consists of the following major components:

Main Frame

The main frame is a fabricated steel structure which houses all the main components such as turn table assembly, tyre drive unit, rasp column assembly, pneumatic and electrical controls.

Turn Table Assembly

The turn table assembly is mounted on the bottom of the main frame which carries the rasp column assembly with the rasp motor. The assembly has two independent screw rods which facilitates the movement of the table and setting the buffing are which is motorised. Since the movements are motorised the controls are controlled with the help of sensors provided on the base of the frame.

Tyre Drive

The tyre drive is mounted on the column of the main frame. The tyre is driven by a 2 hp motor coupled to a gear box on which the expandable hub is fixed for buffing different tyres.

Buffing Head

The buffing head consists of the rasp head assembly. This assembly is driven by a 10 HP motor. The rasp hood outlet is to be connected to a dust extractor for removal of rubber dust. This column is mounted on a platform which has the facility to change the degree for buffing tyres on the shoulders. The control panel is conveniently located for easy operation. The column also is provided with a water spraying system - the rasp blades, a delugger and a brake to prevent the movement of the column.

Electrical Panel

This is located on the column of the main frame. All electrical components are located inside the panel.

Pneumatic Circuit

The pneumatic circuit is located below the electrical panel and is controlled at the operating panel.

Tyre Lift

A tyre lift is provided for easy loading / unloading of tyres onto the expanding rim.

02 Specifications

Mo	BF 5D
	MA11 5D - X*
Tyre Range	6.50 - 14 to 12.00 - 24.5
Air Pressure Requirement (kPa / kg/cm ²)	700 / 7
Dimensions (L x W x H) (mm)	2100 x 1600 x 2250
X* in Cat. No. denotes power supply specifications (V / Hz / ph)	P - 415 / 50 / 3
Electrical Load (kW / hp)	13.05 / 17.5
Weight (kg)	~1110
Installation	Free standing

03 Assembly and Commissioning Tools

Accessories

Standard	Installation kit
	Cyclone filter
	Installation kit for Cyclone filter
Optional	Circumferential reader

Tools

Spanners	
Double end 6 - 36	1 Set each
Ring end 8 - 19	1 Set each
Box Bit 16,17,18,19	1 No.
Adjustable spanner - 1/2"	1 No.
Circlip pliers - 6" (internal and external)	1 No.
Combination pliers - 10"	1 No.
Screw driver set	1 No.
Allen keys (mm) and 7/32", 3/16"	1 Set
Line tester	1 No.
Nylon hammer	1 No.
Insulation tape	1 Roll
Teflon tape	1 Roll
WD 40 rust removing spray	1 No.
Pipe wrench 18"	1 No.

Materials

Electric cable 4 core, 6 sq.mm	Length as per installed position
Gear oil ISO VG-Grade 320 or SAE 140	1 L

04 Installation and Commissioning

Positioning

- The machine can be positioned as a part of the in-house monorail system or as a free standing machine with sufficient space around it.
- It should be placed in a well illuminated space with a good exhaust system.
- The machine does not need a foundation and can be fixed to the floor by using expanding bolts ($\frac{1}{2}$ " or 12 mm) on a level surface. Ensure that it is levelled with the help of a spirit level.
- Position the dust extractor or cyclone filter with a suitable exhaust for the outlet.

Connection

- Connect the cyclone filter through the duct hose to the rasp hood outlet.
- Connect the machine (dust extractor) through the panel board or with a Direct On Line Motor Starter (DOL starter).
- Connect a pneumatic line from the nearest point to the machine.
- Connect a 3 phase - 415 V AC line by using a 4 core 6 sq.mm copper armoured cable.

Lubrication

- Gear oil ISO VG-Grade 320 or SAE 140 or SAE 90 - (approx 1L).

Pressure Setting

- Set the main air line regulator to a pressure of 8 kg/cm² and the miniature regulator on the hub to 1.4 kg/cm²

Expanding Rim Fixing

- Fix the required rim to the hub of the machine. The stem with / without lock should slide into the groove of the segments and should be locked.
- Connect the hose of the rim into the quick coupler on the hub.

05 Pre-Operation Checks

- Remove the shipment clamps that are provided below the rasp column, which are painted red / orange.
- Ensure that the turn table and rasp column break shoe is locked as well as the manual lock is in locked position.
- Never expand the hub without the rim.
- Check for the free movement of the tyre lift.
- Check for the free movement of the expanding hub.
- Check the tyre drive motor for its forward and reverse rotation.
- Check the oil level in the gear box.
- Check the direction of rotation of the rasp motor.
- Check the joystick controls for smooth operation only after you have assured the correct rotation of motors.
- Check the 6 bolts on the shaft connecting the hub.
- Ensure that the main inlet pressure is 8 kg/cm²
- Check if the pointed on the radius scale and shoulder buffing attachment is in order.
- Check the incoming power line for correct voltage.
- Ensure that the lock nut on the rasp spindle shaft is securely tightened.
- Check if all sensors are properly functioning.
- Ensure that the filter bowl is free of water.

06 Operation

1. Decide the buffing radius depending on the wear / size of the tyre.
Refer to the retreader manual for various setting. If required reset the rasp column position.
2. Move the tyre below the tyre lift.
3. Operate the tyre lift for loading the tyre on to the rim.
4. Position the tyre on the centre of the rim.
5. Expand the rim.
6. Insert the tyre inflation hose.
7. Move the turn table to touch the tyre by the help of the joystick.
8. Ensure that the brakes are switched on before starting the motors.
9. Switch on the tyre drive rasp motor and the tyre drive.
10. After the tyre is buffed, refer to the manual for buffing finish.
11. Stop the rasp motor and tyre drive.
12. Measure the width, circumference and record the details in the job card.
13. Remove the inflation hose and allow the air to drain.
14. After buffing, deflate the tyre very carefully by operating the valve to the “release” position very slowly. Sudden releasing will make the expandable hubs to “retract” causing the air inside the tyre to escape through the beads of the tyre with a loud “bang”, which will dislocate the rim segments.

For using the Delugger:

- Mount the delugger on the column and secure it tight.
- Change the rotation of tyre drive to reverse position.
- Move the delugger to touch the crown of the tyre to be delugged.
- Remove sufficient material and the dismantle the delugger for the next process.

07 Do's and Don'ts

Do's

- All moving parts should be cleaned and lubricated periodically.
- Gear box oil should be changed regularly (when colour changes).
- Air filter should be drained at regular intervals.
- Ensure that all gauges indicate correct reading.
- The silencer to be cleaned regularly.
- Ensure that the locking arrangement on the rims are always good.
- Ensure correct pressure for hub and tyre as recommended are maintained.
- Ensure that lock nut on rasp spindle is fastened every time.
- Flip the head assembly at its half life.
- Cooling the blades can be done when temperature is high.
- Clean all dust that has accumulated on the wiper seal.

Don'ts

- Never inflate the hub when a rim is not mounted.
- Do not use blunt blades.
- Do not buff tyre without bristles and the dust extractor hose disconnected.
- Do not buff the tyre by using a rasp column without locking the break switch or manual knob.
- Do not do maintenance work on the machine without switching OFF mains.
- Do not step over the sensors which are fixed on the main frame while doing maintenance work.
- Do not run the machine without oil in the gear box.
- Do not release the air by pulling the safety valve of the expandable rim to deflate the tyre.
- Do not release the hub suddenly. This will cause the air inside the tyre to escape through the bead with a loud bang, dislocating the rim.

08 Troubleshooting

Symptoms / Problems	Possible Causes	Remedies
Machine does not run when switched on	<ol style="list-style-type: none"> 1. Incoming supply failure 2. Improper panel board connection 3. Failure of fuse 4. Emergency switch in locked position 	<ol style="list-style-type: none"> 1. Check incoming supply 2. Check and correct wiring as per circuit diagram 3. Check and replace fuse 4. Release emergency switch
Motor runs on continuous pressing of switch and stops when is released	<ol style="list-style-type: none"> 1. Contactor connection loose 2. Push button contact lock connection loose 3. Push button contact lock failure 	<ol style="list-style-type: none"> 1. Clean contactor terminals and tighten connections 2. Check and rectify 3. Replace contact block
Motor stops while running	<ol style="list-style-type: none"> 1. Motor overload 2. Wrong amperage settingt 	<ol style="list-style-type: none"> 1. Check whether over loaded and correct 2. Reset relay amperage correctly and increase if needed within allowable limit
Motor rasp speed decrease while buffing	<ol style="list-style-type: none"> 1. 'V' belt loose 2. Excess depth of cut 3. Low voltage 	<ol style="list-style-type: none"> 1. Check belt tension - correct or replace 2. Reduce depth of cut (max. 2 mm) 3. Check and correct
'V' belt stretches frequently	<ol style="list-style-type: none"> 1. Belt drive misalignment 2. Wrong belts 3. Poor quality of 'V' belts 4. Pulleys damaged 	<ol style="list-style-type: none"> 1. Check and correct 2. Use only B47 belts 3. Use only good quality belts 4. Replace pulleys
Rasp motors gets over heated	<ol style="list-style-type: none"> 1. 'V' belt too tight 2. Bearing failure 3. Blades blunt 4. Coil of motor weak 	<ol style="list-style-type: none"> 1. Correct belt tension 2. Change bearing, if required 3. Replace blades 4. Check coil with help of meger and rewind if needed

Symptoms / Problems	Possible Causes	Remedies
Motors make humming noise and do not rotate	<ol style="list-style-type: none"> 1. Failure in any one phase supply at motor end 2. Voltage drop 	<ol style="list-style-type: none"> 1. Check 3 phase of supply by using test lamp 2. Check voltage
Machine vibrates while running	<ol style="list-style-type: none"> 1. Machine frame base not levelled on the ground 2. Unbalanced rasp head 3. Uneven tyre surface and heavy lugged tyre 4. Excessive depth of cut 	<ol style="list-style-type: none"> 1. Check base with spirit level and correct accordingly 2. Run rasp head alone and check 3. Check vibration, dynamically balance the head if necessary 4. Do initial buffing with lesser depth of cut till surface evens out. Reduce depth of cut to 1 mm or 2 mm
Noise in tyre drive assembly	<ol style="list-style-type: none"> 1. No oil in the gear box 2. Gear box failure 3. Drive bearing failure 	<ol style="list-style-type: none"> 1. Fill up with suitable lubricating oil up to level 2. Dismantle gear box and check gears for any wear. Replace worn out gears. 3. Replace bearing
Rasp head assembly blades are very loose and chipping off	<ol style="list-style-type: none"> 1. Improper setting of aluminium spacer in rasp head 2. Tighten the lock out 	<ol style="list-style-type: none"> 1. Check and correct 2. Check and correct
Rubber dust does not get extracted fully	<ol style="list-style-type: none"> 1. Accumulation of rubber dust in bin, flexible hose and rasp head column 2. Blower motor running in reverse direction 3. Leaky joint and bin sealing 	<ol style="list-style-type: none"> 1. Empty bins, clean hose etc. 2. Check and correct 3. Check and correct
Rubber dust comes out of cyclone filter's outlet pipe	<ol style="list-style-type: none"> 1. Over flowing bin 	<ol style="list-style-type: none"> 1. Empty the bin

Symptoms / Problems	Possible Causes	Remedies
Tyre gets buffed eccentrically (more on one shoulder than on the other)	<ol style="list-style-type: none"> 1. Centre line of rasp and centre line of tyre do not match 2. Main shaft may have been shifted little to front or to back 3. Inner spacer of rasp head shifted 4. Alignment of gear box 5. Rim not seating on hub properly 	<ol style="list-style-type: none"> 1. Centre the rasp head assembly in line with the tyre 2. Loosen bolts, re-tighten at correct position 3. Adjust the spacer for correct cantering 4. Check and correct 5. Check and correct
Tyres get buffed eccentrically (excessive buffing on one point, less buffing on diametrically opposite point)	<ol style="list-style-type: none"> 1. Radial run out in rim 	<ol style="list-style-type: none"> 1. Check and replace stems
Inflation pressure is not fully attained in tyre	<ol style="list-style-type: none"> 1. Air leakage in joints 2. Restricted air flow through air hose line 3. Air regulator not working 4. Bead leak in tyre 	<ol style="list-style-type: none"> 1. Check and rectify joints 2. Check hose for any bending or twisting causing smaller air flow 3. Check regulated air pressure by fitting another gauge in line if gauge not reading, dismantle regulator and rectify or replace 4. Reject the tyre
Air leaks between bead and expandable rim flap	<ol style="list-style-type: none"> 1. Expandable hub pressure low 2. Wear in stems 	<ol style="list-style-type: none"> 1. Check air pressure in hub and correct 2. Check and replace worn stems
When main airline pressure is opened, air starts leaking continuously	<ol style="list-style-type: none"> 1. Insufficient incoming pressure 2. Pilot valve failure 	<ol style="list-style-type: none"> 1. Check and correct 2. Check and correct
Jerky movement in the tyre lift	<ol style="list-style-type: none"> 1. Incoming line pressure faulty 2. Hose damaged 3. Seals damaged 4. Flow control valve damaged 	<ol style="list-style-type: none"> 1. Check and adjust air pressure 2. Check and replace 3. Check and replace 4. Check and replace

09 Preventive Maintenance

Name of the Post	Buffer
Name of the Equipment	Buffing Machine
Model No.	BF 5D

S. No.	Activity	Frequency	Acceptance Criteria
1	Clean the machine	Daily	Dust free
2	Drain the water from the air filter	Daily	No water in the filter unit
3	Check tyre inflation pressure is 1.4 kg/cm ²	Daily	Pressure in between - 1.5 ± 0.3 kg/cm ²
4	Check expandable hub pressure is 7.2 kg/cm ²	Daily	Pressure in between - 7.2 ± 0.5 kg/cm ²
5	Check the condition of buffing blades and reverse or replace if necessary	Daily	No wear and tear in blade teeth and buffed texture is RMA-3/4
6	Clean the cyclone filter bin after buffing every 5 or 7 tyres	Daily	No rubber dust inside the cyclone filter
7	Check the stem with locks / without locks replace if necessary	Daily	Expandable rim should be locked properly
8	Lubricate rubber flap in expandable rim with Silicon Spray	Daily	Tyre fitting should be air tight
9	Check the condition of ceiling wire for tyre lift arrangement	Daily	No damage
10	Lubricate the sliding bar of tyre lifter with graphite grease	Weekly	Properly lubricated and smooth movement of tyre lifter
11	Lubricate the Turn Table Screw rod assembly with graphite grease	Weekly	Properly lubricated and smooth movement of turn table
12	Check the expandable hub mounting bolts and tighten if necessary	Weekly	Bolt should be tightened properly
13	Check the oil level in gear box	Weekly	Top up oil up to visible level
14	Check the rasp drive belt tension to be 10-15 mm or replace with B-47 V-Belt if necessary	Weekly	No wear tear in belt
15	Clean and service the expandable hub assembly	Monthly	All parts in working condition and no wear and tear in assembly part
16	Check the expandable hub safety valve to operate at 2.2 kg/cm ²	Monthly	Safety valve should be open if pressure is more than 2.2 kg/cm ²
17	Flush the gear box oil and replenish with SAE - 90 Oil	Every 250 tyres	Replace the oil

10 Electrical Drawings

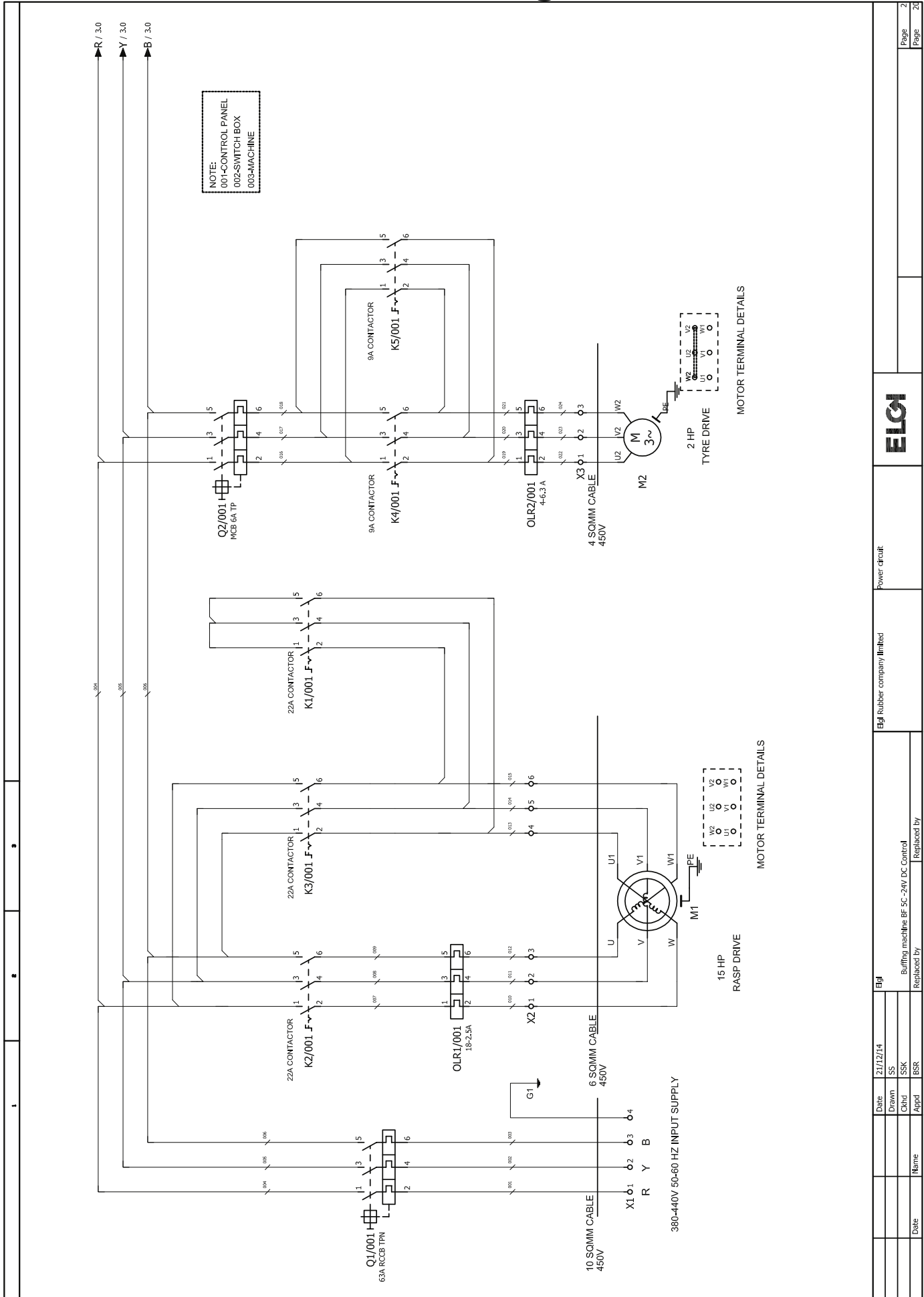

Power circuit

Elgi Rubber company limited

Elgi
Buffing machine BF 5C-24V DC Control
Replaced by

Date 21/12/14
Drawn SS
Ckhd SSK
Appd BSR

Name
Date

Replaced by

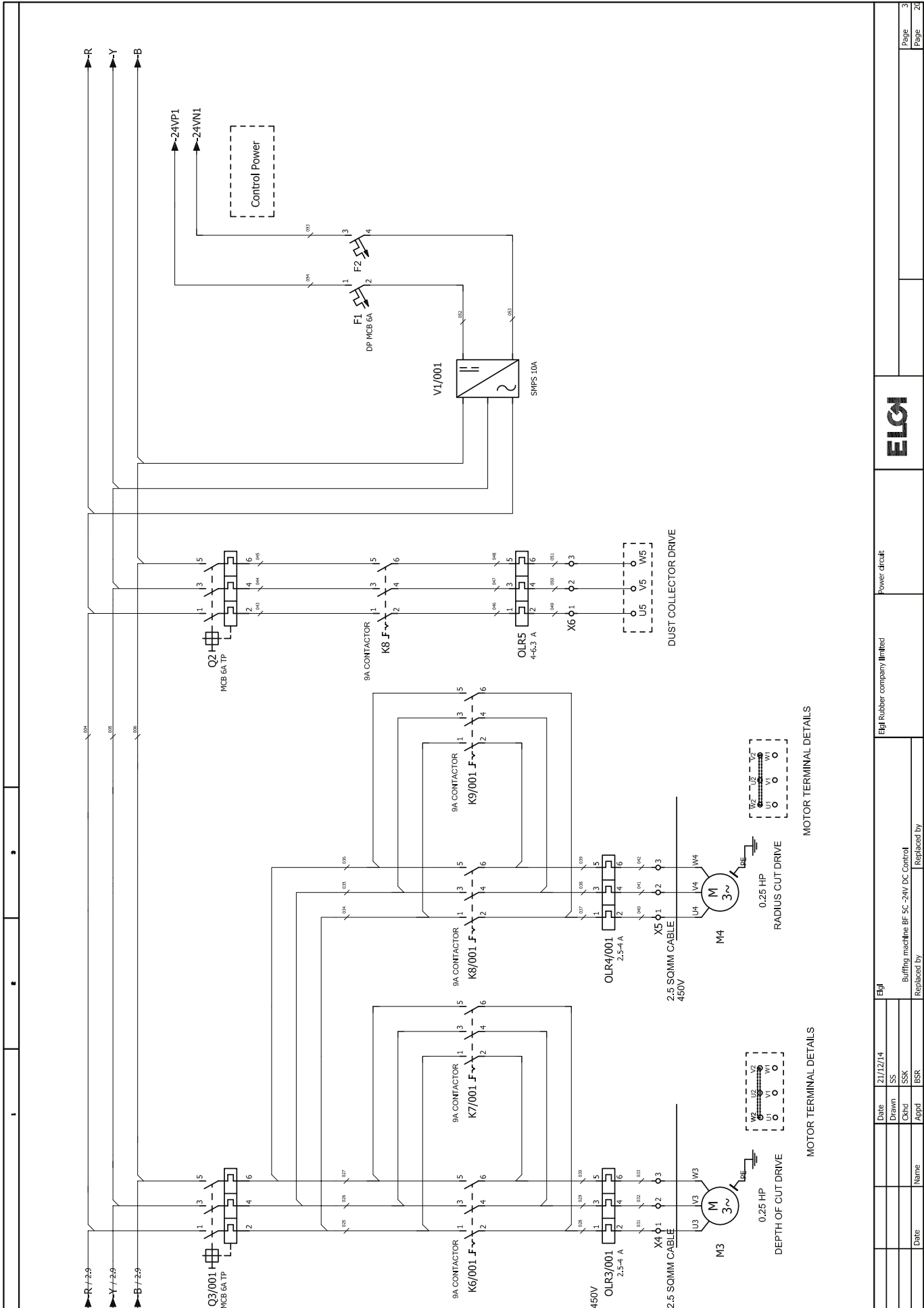

Date		21/12/14	Elgil	Elgil Rubber company limited		Power circuit	
Drawn		SS					
Chkd		SSK		Buffing machine BF-5C-24V DC Control			
Appd		BSR		Replaced by		Replaced by	
Date				Name		Page	
						3	
						24	



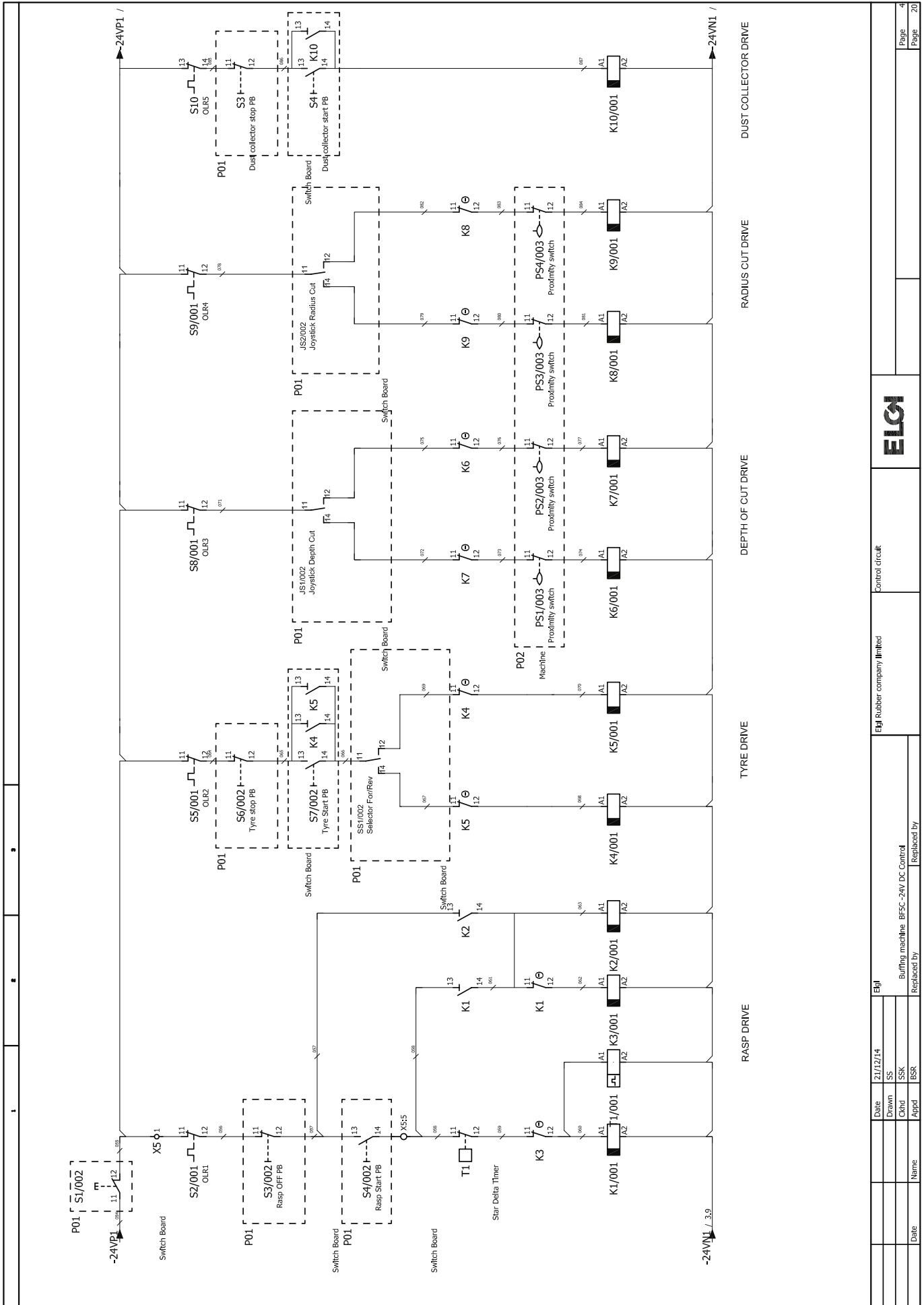

		ELGI		Control circuit		Elgi Rubber company limited		Page 4		
Date	21/12/14	Elgi							Page	20
Drawn	SS									
Ckhd	SSK			Buffing machine BFSC-24V DC Control						
Appd	BSR			Replaced by						
Date		Name								

Terminal diagram

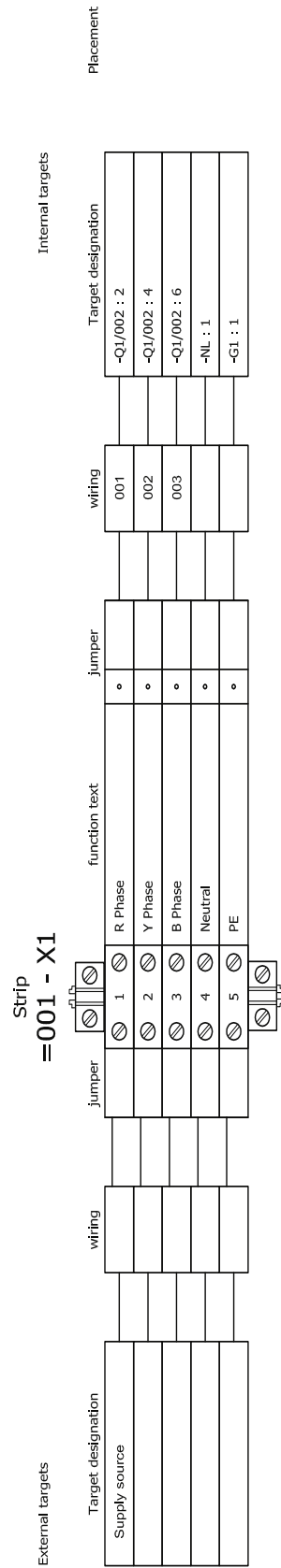

Date		21/12/14		EPI		Terminal diagram=X1		Page 5	
Drawn		SS		EPI Rubber company limited				Page 20	
Chkd		SSK		Buffering machine BF5C 24V DC Control					
Appd		BSR		Replaced by					
Date				Name					

Terminal diagram

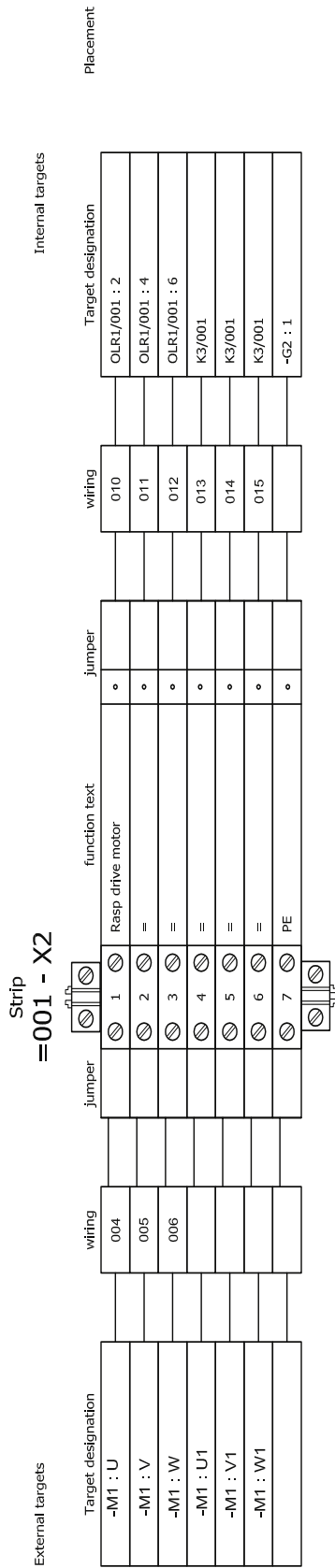

Date	21/12/14	ELPI	Terminal diagram=X2		Page	6
Drawn	SS		ELPI Rubber company limited		Page	20
Chkd	SSK					
Appd	BSR					
			Buffing machine BF5C -24V DC Control			
			Replaced by			

Terminal diagram

External targets		Strip =001-X3		Internal targets			
Target designation	wiring	Jumper	function text	Jumper	wiring	Target designation	Placement
-M2 : U2			Tyre drive motor		022	-OLR2/001 : 2	
-M2 : V2			=		023	-OLR2/001 : 4	
-M2 : W2			=		024	-OLR2/001 : 6	
			PE			-G3 : 1	
-M3 : U3			Depth of cut motor		031	-OLR3/001 : 2	
-M3 : V3			=		032	-OLR3/001 : 4	
-M3 : W3			=		033	-OLR3/001 : 6	
			PE			-G4 : 1	
-M4 : U4			Radius cut motor		040	-OLR4/001 : 2	
-M4 : U4			=		041	-OLR4/001 : 4	
-M4 : W4			=		042	-OLR4/001 : 6	
			PE			-G5 : 1	
-M5 : U5			Dust collector		049	-OLR5/001 : 2	
-M5 : U5			=		050	-OLR5/001 : 4	
-M5 : W5			=		051	-OLR5/001 : 6	
			PE			-G6 : 1	

Date	21/12/14	ELPI	Terminal diagram=X3	Page	7
Drawn	SS			Page	20
Chkd	SSK				
Appd	BSR				
Name		ELPI Rubber company limited		ELPI	
Date		Buffing machine BF5C 24V DC Control			
		Replaced by			

Terminal diagram

Strip
=001- X4

External targets

Internal targets

Target designation	wiring	jumper	function text	jumper	wiring	wiring	Target designation	wiring	Placement
S1/002			EMP	•			F1/001 : 1	064	
S2/002			OLR	•			S1/002 : 12	065	
S3/002			Rasp off PB	•			S2/001 : 12	056	
S4/002			Rasp on PB	•			S3/002 : 12	057	
T1/001			Star delta timer	•			S4/002 : 14	058	
S6 /002			Tyre stop PB	•			S5/001 : 12	064	
S7/002			Tyre on PB	•			S6/002 : 12	065	
SS1/002			Tyre selector For/Rev	•			S7/002 : 14	066	
K4/001			Tyre For	•			SS1/002 : 14	067	
K5/001			Tyre Rev	•			SS1/002 : 12	070	
JS1/002			Joystick depth of cut	•			S8/001 : 12	071	
PS1/003			Proximity switch	•			JS1/002 : 14	073	
K6/001			Depth of cut For	•			PS1/003 : 14	074	
P-S2/003			Proximity switch	•			JS1/002 : 14	076	
K7/001			Depth of cut Rev	•			PS2/003 : 12	077	
JS2/002			Joystick radius cut	•			S9/001 : 12	078	
P-S3/003			Proximity switch	•			JS2/002 : 14	080	
K8/001			Radius cut For	•			P-S3/003 : 12	081	
P-S4/003			Proximity switch	•			JS2/002 : 12	083	
K9/001			Radius cut Rev	•			P-S4/003 : 12	084	
K8/001			Dust collector stop PB	•			S10/001 : 12	085	
P-S4/003			Dust collector start PB	•			S11/001 : 12	086	
K9/001			Dust collector ON	•			S12/001 : 14	087	

Date	21/12/14	ELPI	Terminal diagram → X4	Page	8
Drawn	SS		ELPI Rubber company limited	Page	20
Chkd	SSK				
Date			Buffing machine BF5C -24V DC Control		
Name	SS		Replaced by		
	BSR				

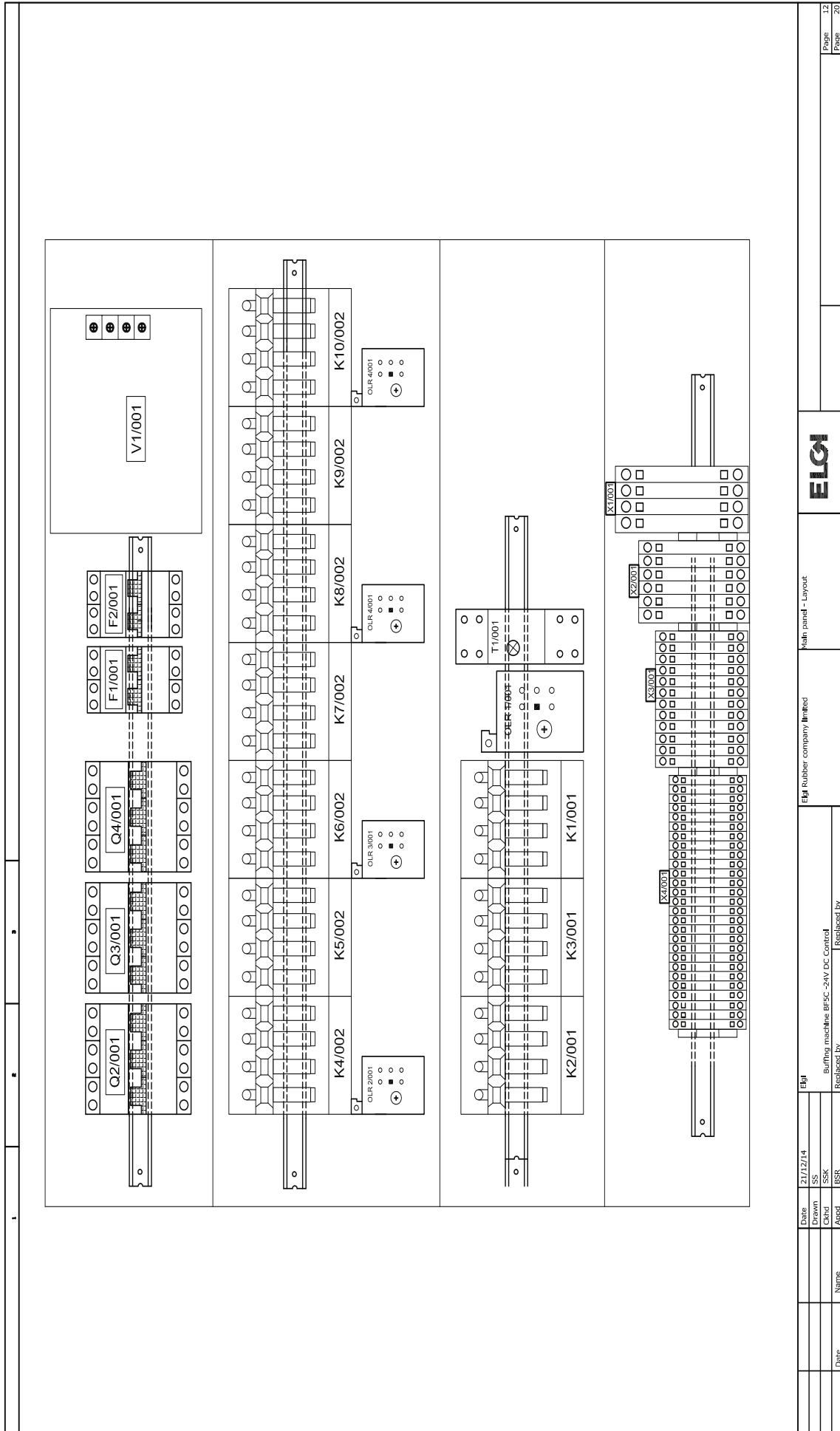

Date	21/12/14	ELPI	ELPI Rubber company limited	Main panel - Layout	Page	12
Drawn	SS				Page	20
Chkd	SSK		Buffing machine BF5C 24V DC Control			
Appd	BSR		Replaced by			
		Name				
		Date				

11 Pneumatic Circuit

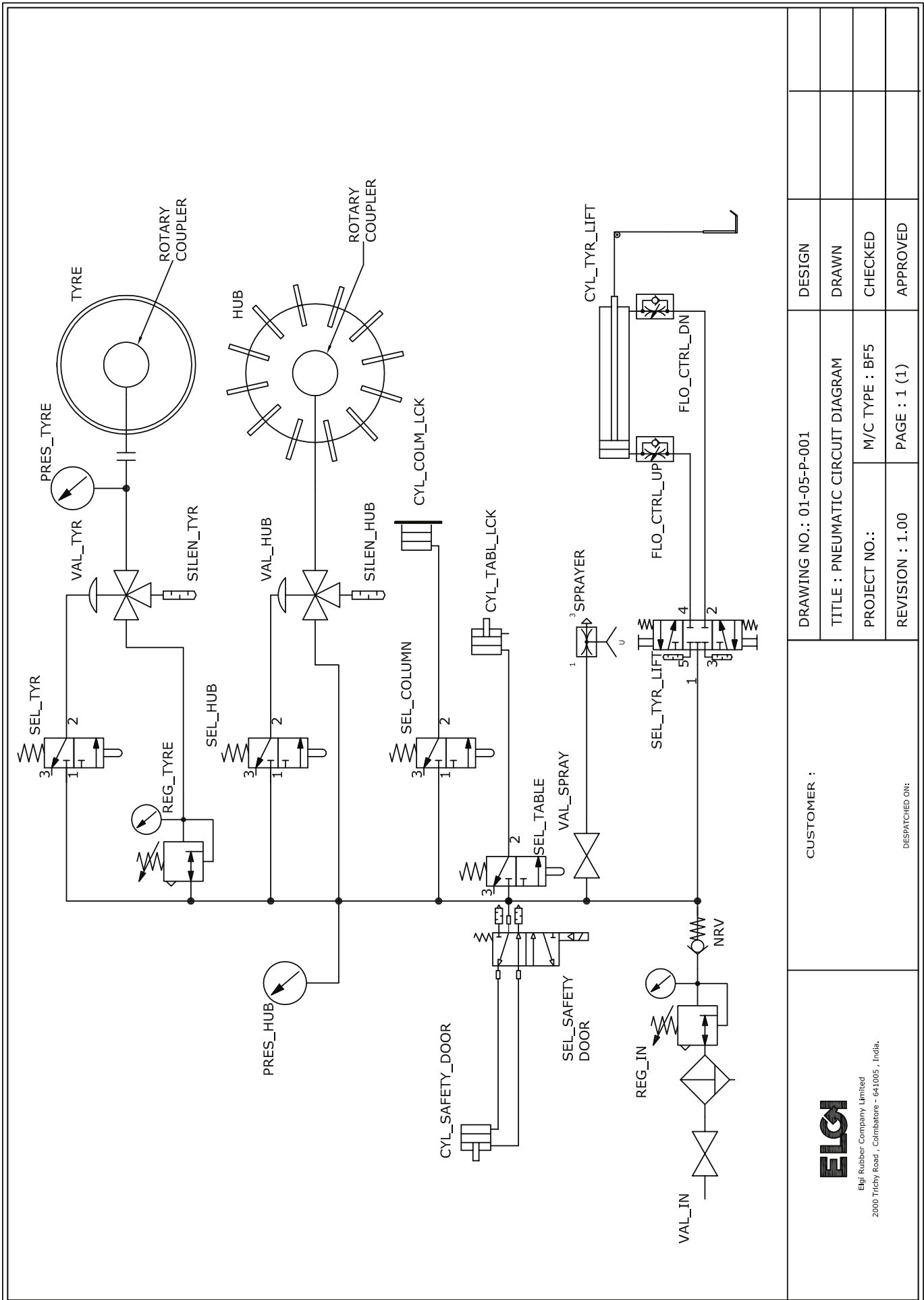

<p>ELGI Elgi Rubber Company Limited 2000 Trichy Road, Coimbatore - 641005, India.</p>	CUSTOMER :		DRAWING NO.: 01-05-P-001		DESIGN
	DESPATCHED ON:		TITLE : PNEUMATIC CIRCUIT DIAGRAM		DRAWN
			PROJECT NO.: M/C TYPE : BF5		CHECKED
			REVISION : 1.00		APPROVED

12 Parts List

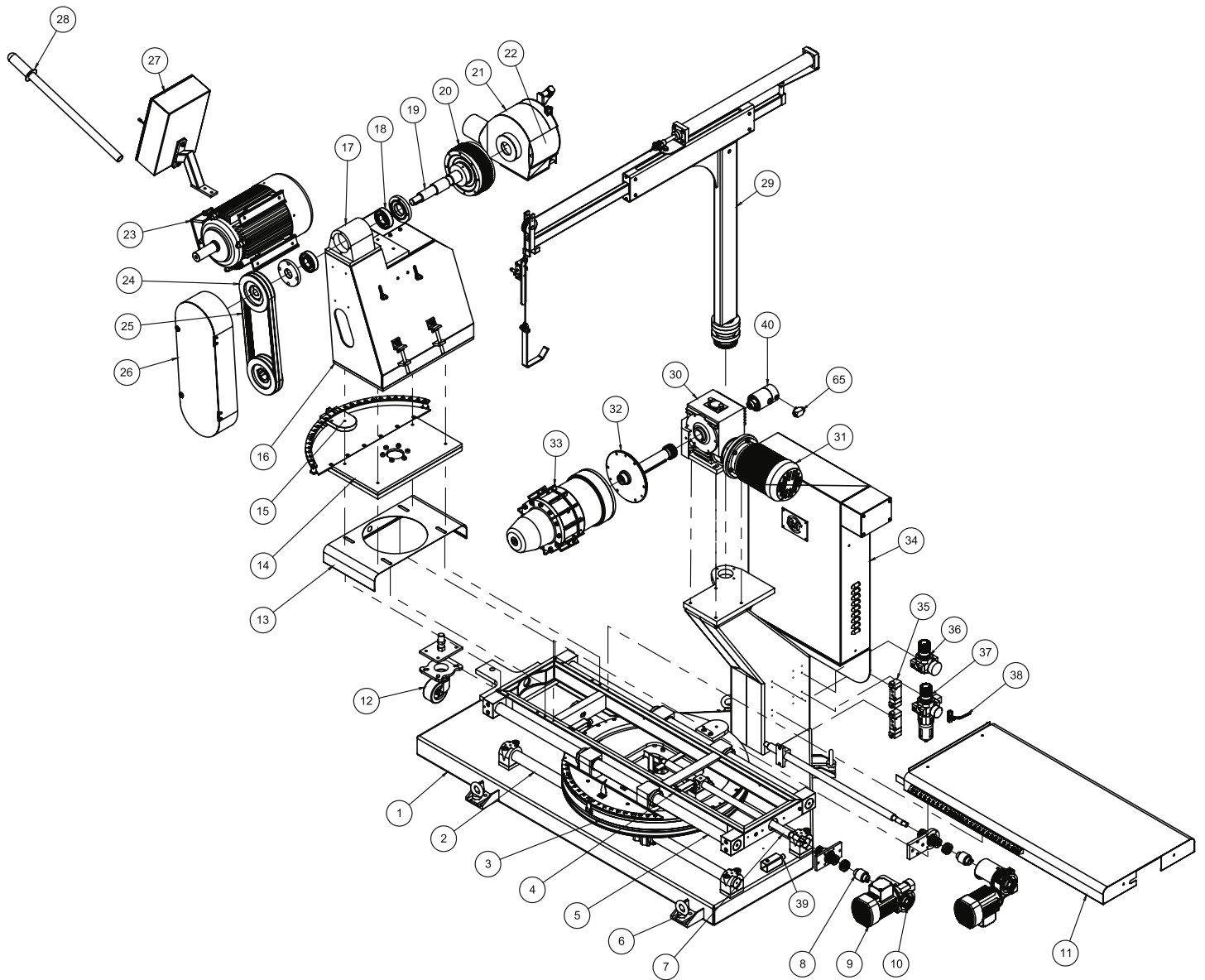

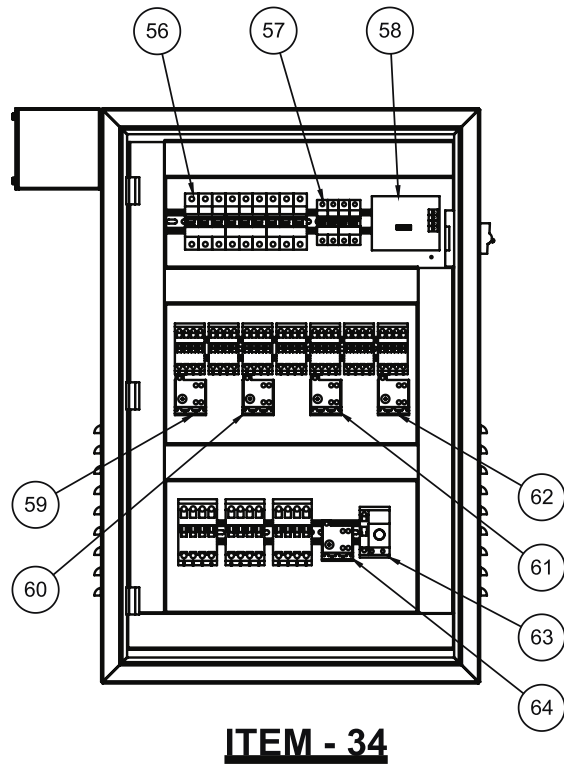
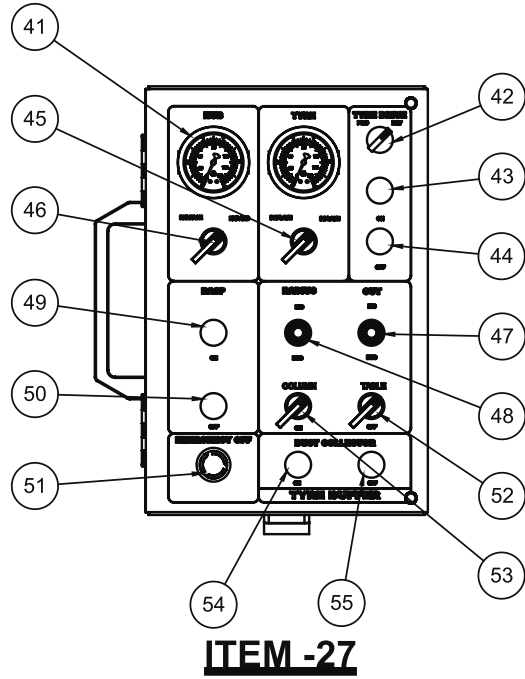

Parts List - BOM

S. No.	Order Code	Description	UOM	Qty.
1	MA115D/1	Main Frame	Nos	1
2	MA115D/2	Shaft Cross Feed	Nos	2
3	MA115D/3	Turn Table Double Bearing Assembly (dual)	Nos	1
4	MA115D/4	Slide Frame	Nos	1
5	MA115D/5	Shaft Turn Table	Nos	2
6	MA115D/6	Eye Bolt M20	Nos	4
7	MA115D/7	Screw Rod Cross Feed /turn Table	Nos	2
8	MA115D/8	Gear Coupling-m19 Machined	Nos	2
9	MA115D/9	Motor 0.25hp 4pole	Nos	2
10	MA115D/10	Worm Gear Box	Nos	2
11	MA115D/11	Cover Slide Frame	Mtr	1
12	MA115D/12	Caster Wheel / Hsc2 / Pt / N100 / Swivel	Nos	1
13	MA115D/13	Cover Saddle Rasp Column	Nos	1
14	MA115D/14	Top Saddle Assy (rasp Column)	Nos	1
15	MA115D/15	Rasp Column Brake Disc	Nos	1
16	MA115D/16	Rasp Column	Nos	1
17	MA115D/17	Bearing Housing With End Cover	Nos	1
18	MA115D/18	Ball Bearing 6308zz / SKF	Nos	2
19	MA115D/19	Rasp Spindle	Nos	1
20	MA115D/20	Rasp Head Assembly (Jet Hub)	Nos	1
21	MA115D/21	Rasp Hood	Nos	1
22	MA115D/22	Safety Door Rasp Head	Nos	1
23	MA115D/23	Motor 15hp	Nos	1
24	MA115D/24	Pulley Taper Lock	Nos	2
25	MA115D/25	V-belt (B-47)	Nos	2
26	MA115D/26	Belt Guard	Nos	1
27	MA115D/27	Control Switch Board Assembly-Control 24V DC	Nos	1
28	MA115D/28	Rasp Handle	Nos	1
29	MA115D/29	Tyre Lift	Nos	1
30	MA115D/30	Tyre Drive Gear Box Assembly	Nos	1
31	MA115D/31	Motor 2hp	Nos	1
32	MA115D/32	Main Shaft	Nos	1
33	MA115D/33	Expanding Hub - EH5	Nos	1

S. No.	Order Code	Description	UOM	Qty.
34	MA115D/34	Control Panel Board Assembly-Control 24V DC	Nos	1
35	MA115D/35	3/2 Single Pilot Operated Valve	Nos	2
36	MA115D/36	Regulator LR 1/4-D Mini	Nos	1
37	MA115D/37	Air Filter Cum Regulator LFR 1/4 D Mini	Nos	1
38	MA115D/38	Ball Valve - 1/4"	Nos	1
39	MA115D/39	Inductive Proximity Switch	Nos	4
40	MA115D/40	Rotary Seal Coupling (Dual PR)	Nos	1
41	MA115D/41	Pressure Gauge 0 to 10 KGF	Nos	2
42	MA115D/42	Switch Forward Reverse - Tyre Drive	Nos	1
43	MA115D/43	Push Button On - Tyre Drive	Mtr	1
44	MA115D/44	Push Button Off - Tyre Drive	Nos	1
45	MA115D/45	Selector Switch - Tyre Inflation / Deflation	Nos	1
46	MA115D/46	Selector Switch - Hub Inflation / Deflation	Nos	1
47	MA115D/47	Joystick Depth Off Cut Increase / Decrease	Nos	1
48	MA115D/48	Joystick Radius Increase / Decrease	Nos	1
49	MA115D/49	Push Button On - Rasp Drive	Nos	1
50	MA115D/50	Push Button Off - Rasp Drive	Nos	1
51	MA115D/51	Emergency Off Button	Nos	1
52	MA115D/52	Selector Switch - Table Lock / Unlock	Nos	1
53	MA115D/53	Selector Switch - Column Lock / Unlock	Nos	1
54	MA115D/54	Push Button On - Dust Collector	Nos	1
55	MA115D/55	Push Button Off - Dust Collector	Nos	1
56	MA115D/56	MCB 16A Q2/Q3/Q4	Nos	1
57	MA115D/57	DP MCB 6A	Nos	1
58	MA115D/58	Smbs 6A	Nos	1
59	MA115D/59	Contractor 24V-Depth Of Cut	Nos	1
60	MA115D/60	Contractor 24V-Radius	Nos	1
61	MA115D/61	Contractor 24V-Tyre Drive	Nos	1
62	MA115D/62	Contractor 24V-Dust Collector	Nos	1
63	MA115D/63	Timer	Nos	1
64	MA115D/64	Contractor 24V-Rasp Motor	Nos	1
65	MA115D/65	Rapid Relief Valve	Nos	1